



8-BIT MICROCONTROLLER

GENERAL DESCRIPTION

The W78C52C microcontroller supplies a wider frequency range than most 8-bit microcontrollers on the market. It is compatible with the industry standard 80C52 microcontroller series.

The W78C52C contains four 8-bit bidirectional parallel ports, three 16-bit timer/counters, and a serial port. These peripherals are supported by a six-source, two-level interrupt capability. There are 256 bytes of RAM and an 8 K byte mask ROM for application programs.

The W78C52C microcontroller has two power reduction modes, idle mode and power-down mode, both of which are software selectable. The idle mode turns off the processor clock but allows for continued peripheral operation. The power-down mode stops the crystal oscillator for minimum power consumption. The external clock can be stopped at any time and in any state without affecting the processor.

FEATURES

- 8-bit CMOS microcontroller
- Fully static design
- Low standby current at full supply voltage
- DC-40 MHz operation
- 256 bytes of on-chip scratchpad RAM
- 8K bytes of on-chip mask ROM
- 64K bytes program memory address space
- 64K bytes data memory address space
- Four 8-bit bidirectional ports
- Three 16-bit timer/counters
- One full duplex serial port
- Boolean processor
- Six-source, two-level interrupt capability
- Built-in power management
- Code protection
- Packages:
 - DIP 40: W78C52C-16/24/33/40
 - PLCC 44: W78C52CP-16/24/33/40
 - QFP 44: W78C52CF-16/24/33/40



PIN CONFIGURATIONS

40-Pin DIP (W78C52C)

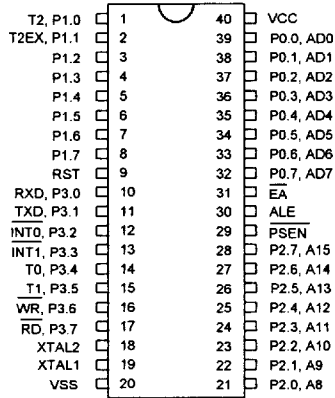

44-Pin PLCC (W78C52CP)

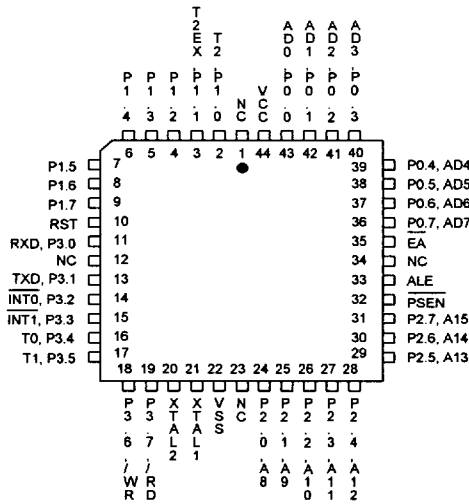

44-Pin QFP (W78C52CF)

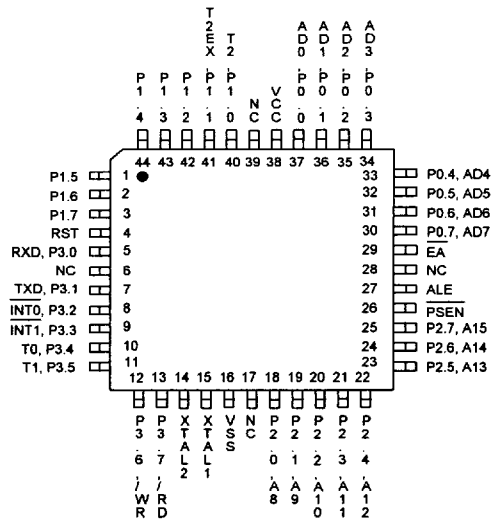



PIN DESCRIPTION

P0.0–P0.7

Port 0, Bits 0 through 7. Port 0 is a bidirectional I/O port. This port also provides a multiplexed low order address/data bus during accesses to external memory.

P1.0–P1.7

Port 1, Bits 0 through 7. Port 1 is a bidirectional I/O port with internal pull-ups. Pins P1.0 and P1.1 also serve as T2 (Timer 2 external input) and T2EX (Timer 2 capture/reload trigger), respectively.

P2.0–P2.7

Port 2, Bits 0 through 7. Port 2 is a bidirectional I/O port with internal pull-ups. This port also provides the upper address bits for accesses to external memory.

P3.0–P3.7

Port 3, Bits 0 through 7. Port 3 is a bidirectional I/O port with internal pull-ups. All bits have alternate functions, which are described below:

PIN	ALTERNATE FUNCTION
P3.0	RXD Serial Receive Data
P3.1	TXD Serial Transmit Data
P3.2	$\overline{\text{INT0}}$ External Interrupt 0
P3.3	$\overline{\text{INT1}}$ External Interrupt 1
P3.4	T0 Timer 0 Input
P3.5	T1 Timer 1 Input
P3.6	$\overline{\text{WR}}$ Data Write Strobe
P3.7	$\overline{\text{RD}}$ Data Read Strobe

$\overline{\text{EA}}$

External Address Input, active low. This pin forces the processor to execute out of external ROM. This pin should be kept low for all W78C32 operations.

RST

Reset Input, active high. This pin resets the processor. It must be kept high for at least two machine cycles in order to be recognized by the processor.

ALE

Address Latch Enable Output, active high. ALE is used to enable the address latch that separates the address from the data on Port 0. ALE runs at 1/6th of the oscillator frequency. A single ALE pulse is skipped during external data memory accesses. ALE goes to a high impedance state during reset with a weak pull-up.

$\overline{\text{PSEN}}$



Program Store Enable Output, active low. $\overline{\text{PSEN}}$ enables the external ROM onto the Port 0 address/data bus during fetch and MOVC operations. $\overline{\text{PSEN}}$ goes to a high impedance state during reset with a weak pull-up.

XTAL1

Crystal 1. This is the crystal oscillator input. This pin may be driven by an external clock.

XTAL2

Crystal 2. This is the crystal oscillator output. It is the inversion of XTAL1.

Vss, Vcc

Power Supplies. These are the chip ground and positive supplies.

BLOCK DIAGRAM

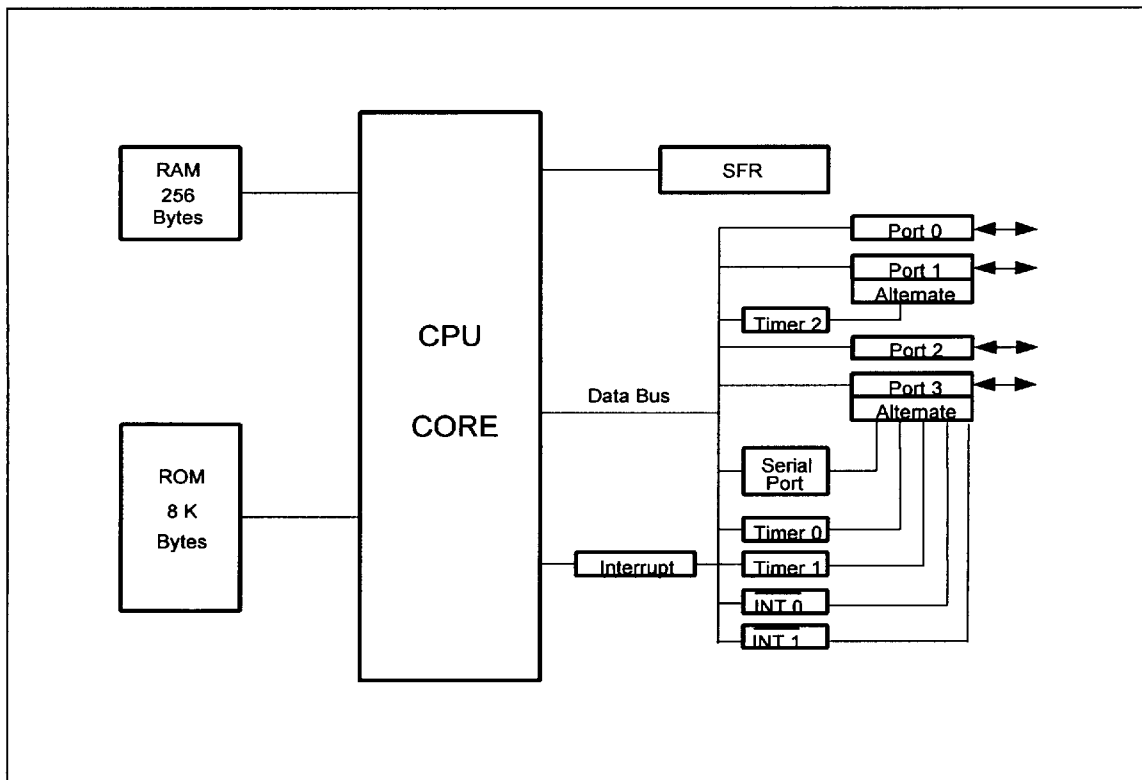



FUNCTIONAL DESCRIPTION

The W78C52C architecture consists of a core controller surrounded by various registers, four general purpose I/O ports, 256 bytes of RAM, three timer/counters, and a serial port. The processor supports 111 different opcodes and references both a 64K program address space and a 64 K data storage space.

Timers 0, 1, and 2

Timers 0, 1, and 2 each consist of two 8-bit data registers. These are called TL0 and TH0 for Timer 0, TL1 and TH1 for Timer 1, and TL2 and TH2 for Timer 2. The TCON and TMOD registers provide control functions for timers 0, 1. The T2CON register provides control functions for Timer 2. RCAP2H and RCAP2L are used as reload/capture registers for Timer 2.

The operations of Timer 0 and Timer 1 are the same as in the W78C51. Timer 2 is a special feature of the W78C52C: it is a 16-bit timer/counter that is configured and controlled by the T2CON register. Like Timers 0 and 1, Timer 2 can operate as either an external event counter or as an internal timer, depending on the setting of bit C/T2 in T2CON. Timer 2 has three operating modes: capture, auto-reload, and baud rate generator. The clock speed at capture or auto-reload mode is the same as that of Timers 0 and 1.

Clock

The W78C52C is designed to be used with either a crystal oscillator or an external clock. Internally, the clock is divided by two before it is used. This makes the W78C52C relatively insensitive to duty cycle variations in the clock.

Crystal Oscillator

The W78C52C incorporates a built-in crystal oscillator. To make the oscillator work, a crystal must be connected across pins XTAL1 and XTAL2. In addition, a load capacitor must be connected from each pin to ground, and a resistor must also be connected from XTAL1 to XTAL2 to provide a DC bias when the crystal frequency is above 24 MHz.

External Clock

An external clock should be connected to pin XTAL1. Pin XTAL2 should be left unconnected. The XTAL1 input is a CMOS-type input, as required by the crystal oscillator. As a result, the external clock signal should have an input one level of greater than 3.5 volts.

Power Management

Idle Mode

The idle mode is entered by setting the IDL bit in the PCON register. In the idle mode, the internal clock to the processor is stopped. The peripherals and the interrupt logic continue to be clocked. The processor will exit idle mode when either an interrupt or a reset occurs.

Power-down Mode

When the PD bit of the PCON register is set, the processor enters the power-down mode. In this mode all of the clocks, including the oscillator are stopped. The only way to exit power-down mode is by a reset.

Reset

*Publication Release Date: June 1996
Revision A2*

W78C52C



The external RESET signal is sampled at S5P2. To take effect, it must be held high for at least two machine cycles while the oscillator is running.

An internal trigger circuit in the reset line is used to deglitch the reset line when the W78C52C is used with an external RC network. The reset logic also has a special glitch removal circuit that ignores glitches on the reset line.

During reset, the ports are initialized to FFH, the stack pointer to 07H, PCON (with the exception of bit 4) to 00H, and all of the other SFR registers except SBUF to 00H. SBUF is not reset.

ABSOLUTE MAXIMUM RATINGS

ITEM	SYMBOL	PARAMETER	MIN.	MAX.	UNIT
1	VCC-VSS	DC Power Supply	-0.3	+7.0	V
2	VIN	Input Voltage	VSS-0.3	VCC+0.3	V
3	TA	Operating Temperature	0	70	°C
4	TST	Storage Temperature	-55	+150	°C

Note: Exposure to conditions beyond those listed under Absolute Maximum Ratings may adversely affect the life and reliability of the device.

DC CHARACTERISTICS

VCC-VSS = 5V ** 10%, TA = 25° C, Fosc = 20 MHz unless otherwise specified.

PARAMETER	SYMBOL	TEST CONDITIONS	SPECIFICATION		UNIT
			MIN.	MAX.	
Operating Voltage	VDD		4.5	5.5	V
Operating Current	IDD	No load VDD = 5.5V	-	30	mA
Idle Current	IIDLE	Idle mode VDD = 5.5V	-	6	mA
Power Down Current	IPWDN	Power-down mode VDD = 5.5V	-	50	μA
Input Current P1, P2, P3	IIN1	VDD = 5.5V VIN = 0V or VDD	-50	+10	μA
Logical 1-to-0 Transition Current P1, P2, P3 (*1)	ITL	VDD = 5.5V VIN = 2.0V (*1)	-650	-	μA
Input Current RST (*2)	IIN2	VDD = 5.5V VIN = VDD	-	+300	μA
Input Leakage Current P0, EA	ILK	VDD = 5.5V 0V < VIN < VDD	-10	+10	μA



DC Characteristics, continued

PARAMETER	SYMBOL	TEST CONDITIONS	SPECIFICATION		UNIT
			MIN.	MAX.	
Output Low Voltage P1, P2, P3	VOL1	V _{DD} = 4.5V I _{OL1} = +2 mA	-	0.45	V
Output Low Voltage ALE, $\overline{\text{PSEN}}$, P0 ^(*3)	VOL2	V _{DD} = 4.5V I _{OL2} = +4 mA	-	0.45	V
Output High Voltage P1, P2, P3	VOH1	V _{DD} = 4.5V I _{OH1} = -100 μ A	2.4	-	V
Output High Voltage ALE, $\overline{\text{PSEN}}$, P0 ^(*3)	VOH2	V _{DD} = 4.5V I _{OH2} = -400 μ A	2.4	-	V
Input Low Voltage (Except RST)	VIL1	V _{DD} = 4.5V	0	0.8	V
Input Low Voltage RST ^(*4)	VIL2	V _{DD} = 4.5V	0	0.8	V
Input Low Voltage XTAL1 ^(*4)	VIL3	V _{DD} = 5.0V	0	0.8	V
Input High Voltage (Except RST)	VIH1	V _{DD} = 5.5V	2.4	V _{DD} + 0.2	V
Input High Voltage RST ^(*4)	VIH2	V _{DD} = 5.5V	3.5	V _{DD} + 0.2	V
Input High Voltage XTAL1 ^(*4)	VIH3	V _{DD} = 5.0V	3.5	V _{DD} + 0.2	V

Notes:

1. Pins of P1, P2 and P3 source a transition current when they are being externally driven from 1 to 0. The transition current reaches its maximum value when t_r is approximately 2V.
2. RST pin has an internal pull-down resistor.
3. P0, ALE, $\overline{\text{PSEN}}$ are in the external access mode.
4. XTAL1 is a CMOS input and RST is a Schmitt trigger input.

Publication Release Date: June 1996
Revision A2



AC CHARACTERISTICS

The AC specifications are a function of the particular process used to manufacture the part, the ratings of the I/O buffers, the capacitive load, and the internal routing capacitance. Most of the specifications can be expressed in terms of multiple input clock periods (TCP), and actual parts will usually experience less than a ± 20 nS variation. The numbers below represent the performance expected from a 1.2 micron CMOS process when using 2 and 4 mA output buffers.

Clock Input Waveform

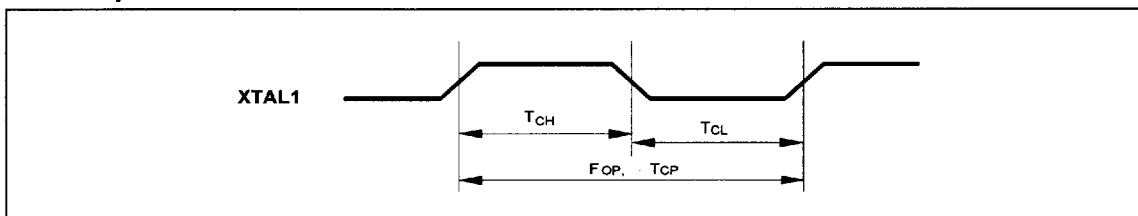

PARAMETER	SYMBOL	MIN.	TYP.	MAX.	UNIT	NOTES
Operating Speed	FOP	0	-	40	MHz	1
Clock Period	TCP	25	-	-	nS	2
Clock High	TCH	10	-	-	nS	3
Clock Low	TCL	10	-	-	nS	3

Notes:

1. The clock may be stopped indefinitely in either state.
2. The TCP specification is used as a reference in other specifications.
3. There are no duty cycle requirements on the XTAL1 input.

Program Fetch Cycle

PARAMETER	SYMBOL	MIN.	TYP.	MAX.	UNIT	NOTES
Address Valid to ALE Low	TAAS	1 TCP- Δ	-	-	nS	4
Address Hold from ALE Low	TAAH	1 TCP- Δ	-	-	nS	1, 4
ALE Low to PSEN Low	TAPL	1 TCP- Δ	-	-	nS	4
PSEN Low to Data Valid	TPDA	-	-	2 TCP	nS	2
Data Hold after PSEN High	TPDH	0	-	1 TCP	nS	3
Data Float after PSEN High	TPDZ	0	-	1 TCP	nS	
ALE Pulse Width	TALW	2 TCP- Δ	2 TCP	-	nS	4
PSEN Pulse Width	TPSW	3 TCP- Δ	3 TCP	-	nS	4

Notes:

1. P0.0-P0.7, P2.0-P2.7 remain stable throughout entire memory cycle.
2. Memory access time is $3 \overline{\text{TCP}}$.
3. Data have been latched internally prior to $\overline{\text{PSEN}}$ going high.
4. " Δ " (due to buffer driving delay and wire loading) is 20 nS.

Data Read Cycle



PARAMETER	SYMBOL	MIN.	TYP.	MAX.	UNIT	NOTES
ALE Low to \overline{RD} Low	TDAR	3 $T_{CP-\Delta}$	-	3 $T_{CP+\Delta}$	nS	1, 2
\overline{RD} Low to Data Valid	TDDA	-	-	4 T_{CP}	nS	1
Data Hold from \overline{RD} High	TDDH	0	-	2 T_{CP}	nS	
Data Float from \overline{RD} High	TDDZ	0	-	2 T_{CP}	nS	
\overline{RD} Pulse Width	TDRD	6 $T_{CP-\Delta}$	6 T_{CP}	-	nS	2

Notes:

1. Data memory access time is 8 $\overline{\Phi}$.
2. " Δ " (due to buffer driving delay and wire loading) is 20 nS.

Data Write Cycle

ITEM	SYMBOL	MIN.	TYP.	MAX.	UNIT
ALE Low to \overline{WR} Low	TDAW	3 $T_{CP-\Delta}$	-	3 $T_{CP+\Delta}$	nS
Data Valid to \overline{WR} Low	TDAD	1 $T_{CP-\Delta}$	-	-	nS
Data Hold from \overline{WR} High	TDWD	1 $T_{CP-\Delta}$	-	-	nS
\overline{WR} Pulse Width	TDWR	6 $T_{CP-\Delta}$	6 T_{CP}	-	nS

Note: " Δ " (due to buffer driving delay and wire loading) is 20 nS.

Port Access Cycle

PARAMETER	SYMBOL	MIN.	TYP.	MAX.	UNIT
Port Input Setup to ALE Low	TPDS	1 T_{CP}	-	-	nS
Port Input Hold from ALE Low	TPDH	0	-	-	nS
Port Output to ALE	TPDA	1 T_{CP}	-	-	nS

Note: Ports are read during S5P2, and output data becomes available at the end of S6P2. The timing data are referenced to ALE, since it provides a convenient reference.



TIMING WAVEFORMS

Program Fetch Cycle

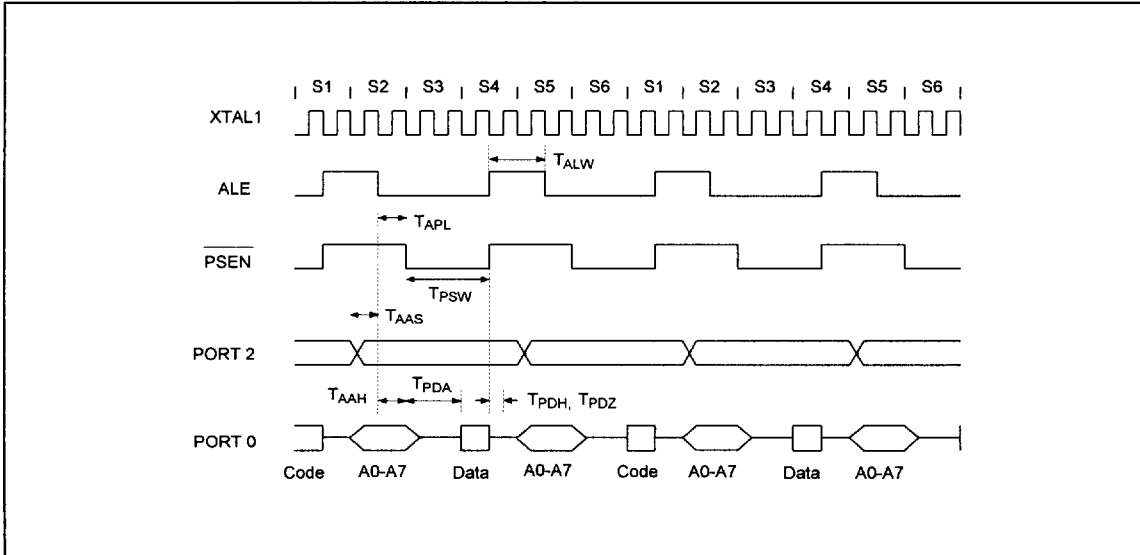

Data Read Cycle

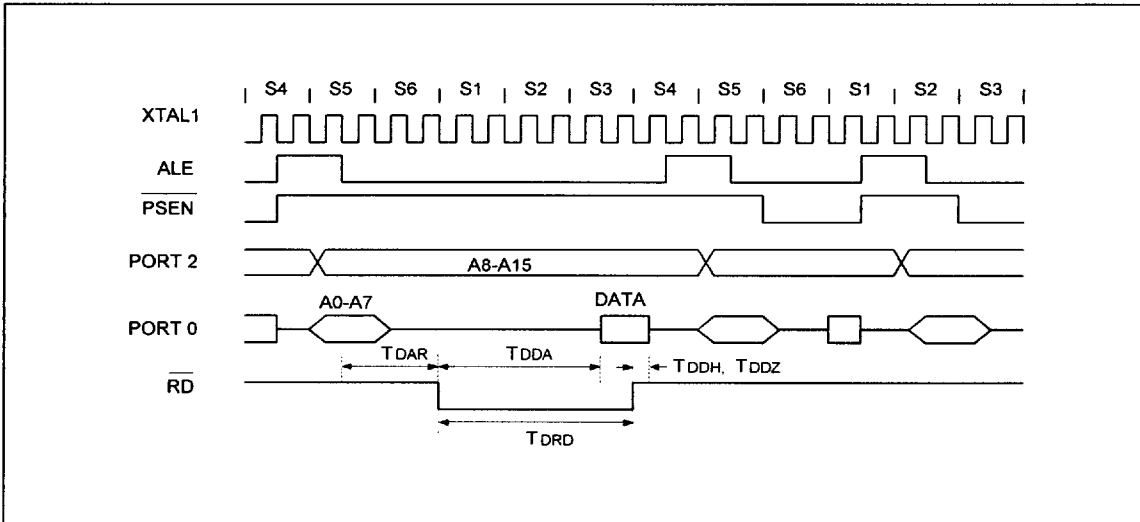



Data Write Cycle

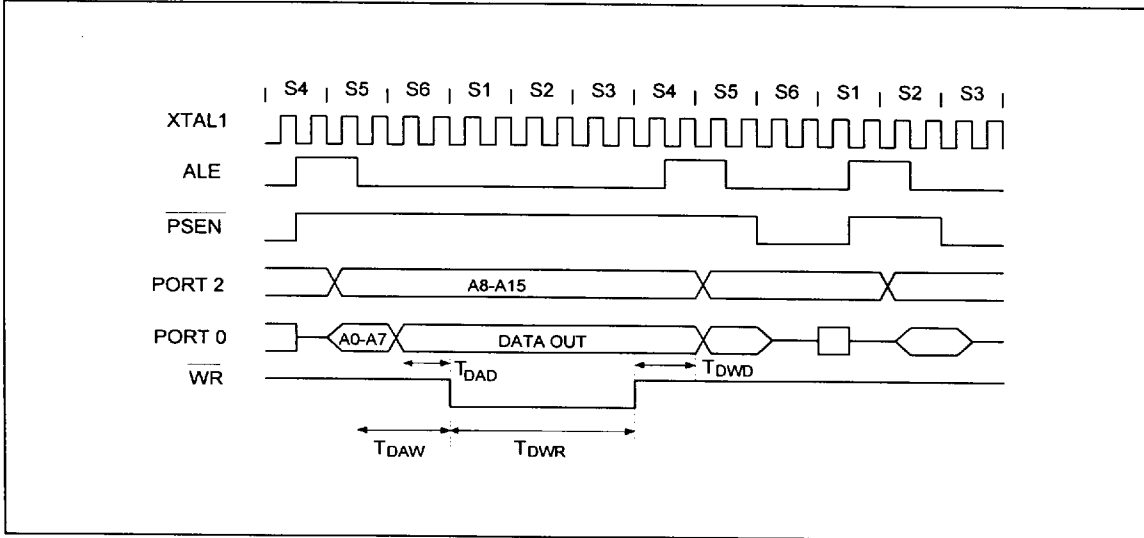

Port Access Cycle

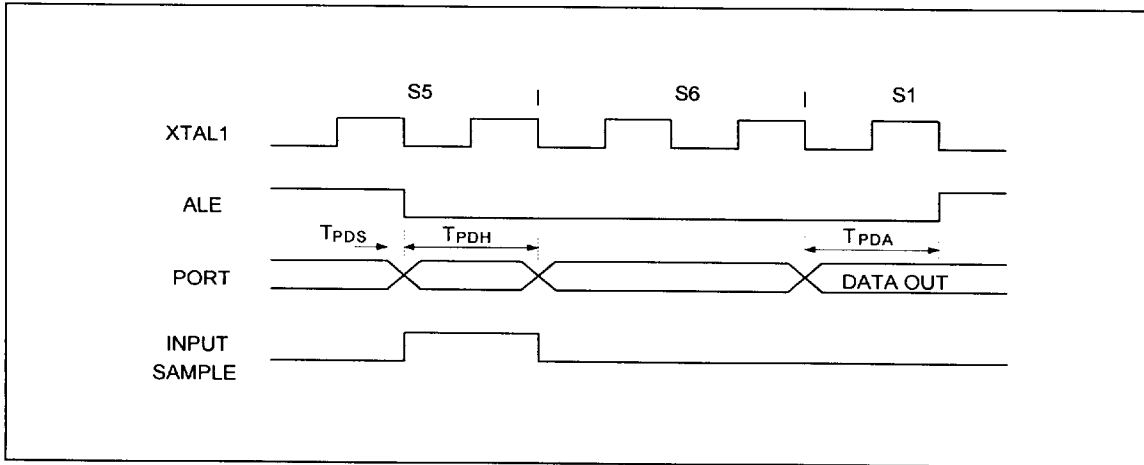



TYPICAL APPLICATION CIRCUIT

Expanded External Program Memory and Crystal

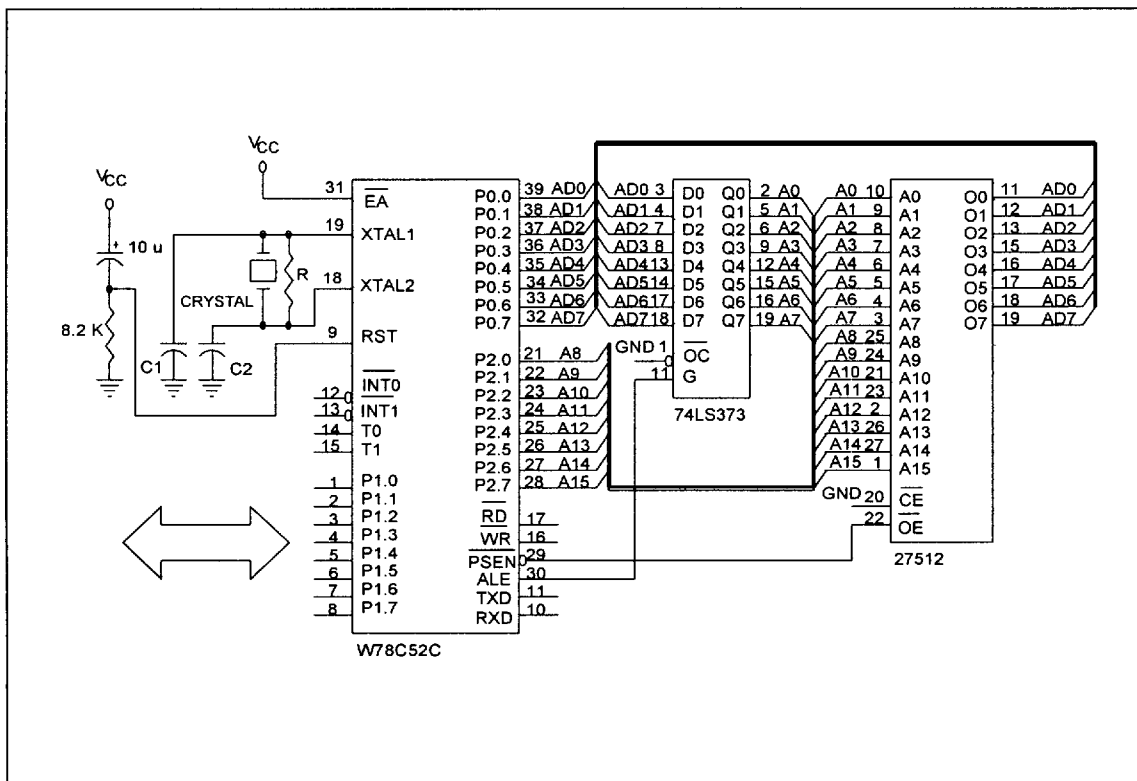

Figure A

CRYSTAL	C1	C2	R
16 MHz	30P	30P	-
24 MHz	15P	15P	-
33 MHz	10P	10P	6.8K
40 MHz	5P	5P	6.8K

Above table shows the reference values for crystal applications.

Note: C1, C2, R components refer to Figure A.



PACKAGE DIMENSIONS

40-pin DIP

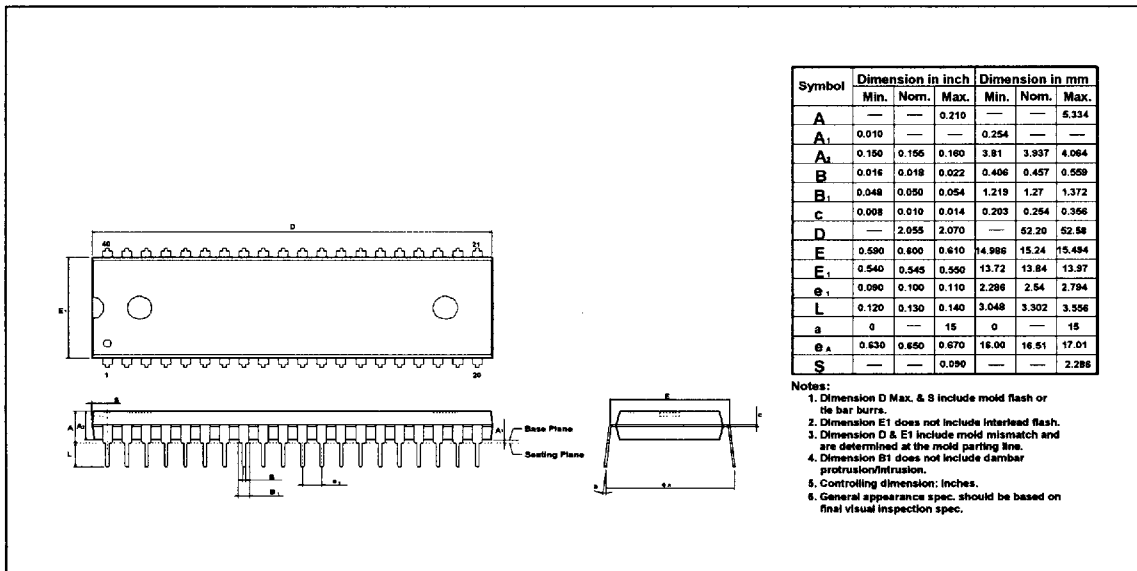

44-pin PLCC

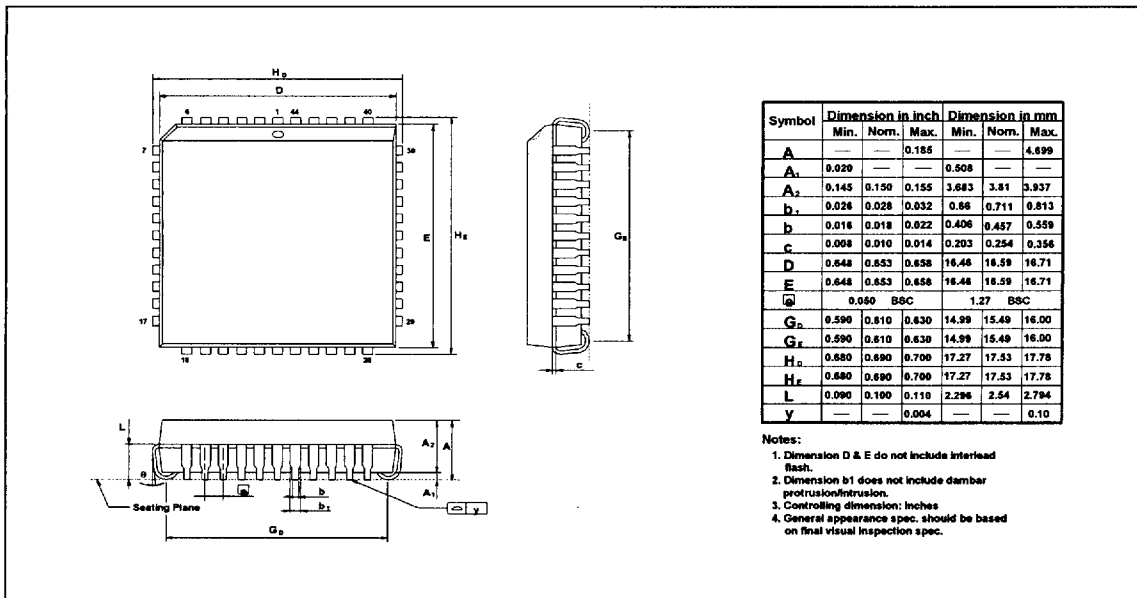



44-pin QFP

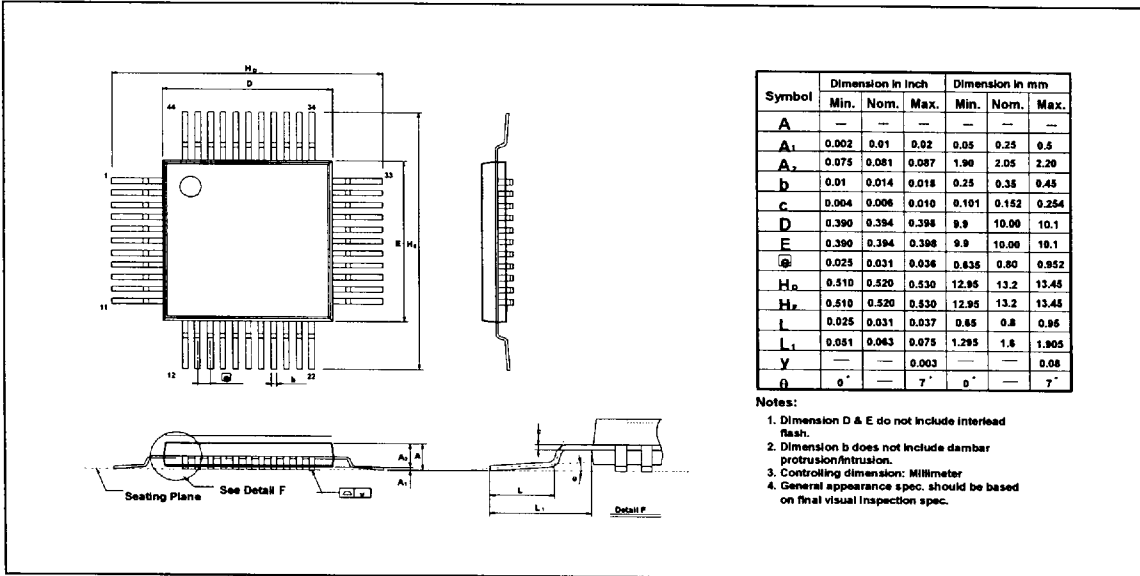

Headquarters

No. 4, Creation Rd. III,
 Science-Based Industrial Park,
 Hsinchu, Taiwan
 TEL: 886-3-5770066
 FAX: 886-3-5792697
 http://www.winbond.com.tw/
 Voice & Fax-on-demand: 886-2-7197006

Taipei Office

11F, No. 115, Sec. 3, Min-Sheng East Rd.,
 Taipei, Taiwan
 TEL: 886-2-7190505
 FAX: 886-2-7197502

Winbond Electronics (H.K.) Ltd.

Rm. 803, World Trade Square, Tower II,
 123 Hoi Bun Rd., Kwun Tong,
 Kowloon, Hong Kong
 TEL: 852-27516023
 FAX: 852-27552064

Winbond Electronics North America Corp.

Winbond Memory Lab.
 Winbond Microelectronics Corp.
 Winbond Systems Lab.
 2730 Orchard Parkway, San Jose,
 CA 95134, U.S.A.
 TEL: 1-408-9436666
 FAX: 1-408-9436668

Note: All data and specifications are subject to change without notice.

