



# NM25C04 4096-Bit Serial Interface CMOS EEPROM (Serial Peripheral Interface (SPI™) Synchronous Bus)

## General Description

The NM25C04 is a 4096-bit SPI compatible CMOS EEPROM. The NM25C04 is designed for data storage in applications requiring both non-volatile memory and in-system data updates. This EEPROM is well suited for applications using the 68HC11 series of microcontrollers that support the SPI protocol for high speed communication with peripheral devices via a serial bus to reduce pin count. The NM25C04 is implemented in National Semiconductor's single poly, double metal CMOS process which provides superior endurance and data retention.

The serial data transmission of this device requires four signal lines to control the device operation: Chip Select ( $\overline{CS}$ ), Clock (SCK), Serial Data In (SI), and Serial Data Out (SO). All programming cycles are completely self-timed and do not require an erase before WRITE.

BLOCK WRITE protection is provided by programming the STATUS REGISTER with one of four levels of write protection. Additionally, separate program enable and program disable instructions are provided for data protection.

Hardware data protection is provided by the  $\overline{WP}$  pin to protect against accidental data changes. The  $\overline{HOLD}$  pin allows the serial communication to be suspended without resetting the serial sequence.

## Features

- 4096 bits organized as 512 bytes
- Multiple chips on the same 3-wire bus with separate chip select lines
- Self-timed programming cycle
- Simultaneous programming of 1 to 4 bytes at a time
- Status register can be polled during programming to monitor RDY/BUSY
- Write Protect ( $\overline{WP}$ ) pin and write disable instruction for both hardware and software write protection
- Block write protect feature to protect against accidental writes
- Endurance:  $10^6$  data changes
- Data retention greater than 40 years
- Packages available: 8-pin DIP or 8-pin SO

## Block Diagram

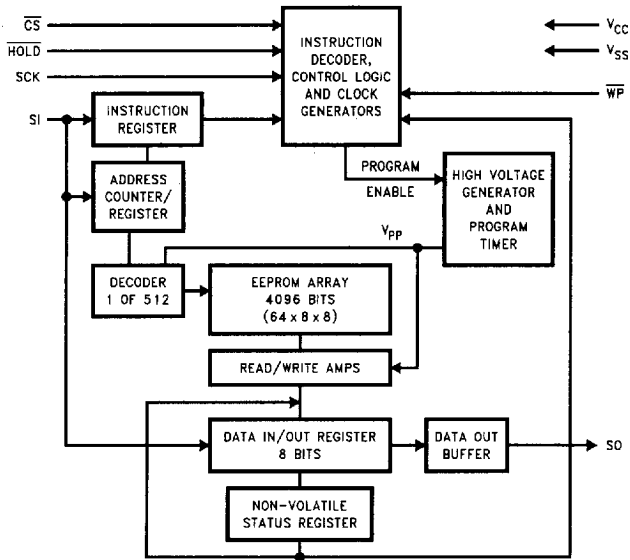

TL/D/11364-1

## Connection Diagram

Dual-In-Line Package (N)  
and SO Package (M8)

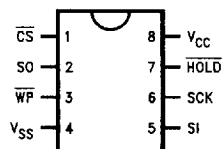

TL/D/11364-2

Pin Names

$\overline{CS}$	Chip Select Input
SO	Serial Data Output
$\overline{WP}$	Write Protect
VSS	Ground
SI	Serial Data Input
SCK	Serial Clock Input
$\overline{HOLD}$	Suspends Serial Input
VCC	Power Supply

## Ordering Information

### Commercial Temperature Range (0°C to +70°C)

Order Number
NM25C04N
NM25C04M8

### Extended Temperature Range (-40°C to +85°C)

Order Number
NM25C04EN
NM25C04EM8

### Military Temperature Range (-55°C to +125°C)

Order Number
NM25C04MN
NM25C04MM8

**Absolute Maximum Ratings** (Note 1)

If Military/Aerospace specified devices are required, please contact the National Semiconductor Sales Office/Distributors for availability and specifications.

Ambient Storage Temperature	-65°C to +150°C
All Input or Output Voltages with Respect to Ground	+6.5V to -0.3V
Lead Temperature (Soldering, 10 sec.)	+300°C
ESD Rating	2000V

**Operating Conditions**

Ambient Operating Temperature	-0°C to +70°C
NM25C04	-40°C to +85°C
NM25C04E	-55°C to +125°C
NM25C04M	4.5V to 5.5V
Power Supply (V <sub>CC</sub> )	

**DC and AC Electrical Characteristics** 4.5V ≤ V<sub>CC</sub> ≤ 5.5V (unless otherwise specified)

Symbol	Parameter	Part Number	Conditions	Min	Max	Units
I <sub>CC</sub>	Operating Current	NM25C04	CS = V <sub>IL</sub>		3	mA
		NM25C04E			3	mA
		NM25C04M			3	mA
I <sub>CCSB</sub>	Standby Current	NM25C04	CS = V <sub>CC</sub>		150	μA
		NM25C04E			150	μA
		NM25C04M			150	μA
I <sub>IL</sub>	Input Leakage		V <sub>IN</sub> = 0V to V <sub>CC</sub>	-1	1	μA
I <sub>OL</sub>	Output Leakage	NM25C04	V <sub>OUT</sub> = 0V to V <sub>CC</sub>	-1	1	μA
		NM25C04E		-1	+1	μA
		NM25C04M		-1	+1	μA
V <sub>IL</sub>	Input Low Voltage			-0.3	0.3 * V <sub>CC</sub>	V
V <sub>IH</sub>	Input High Voltage			0.7 * V <sub>CC</sub>	V <sub>CC</sub> + 0.3	V
V <sub>OL</sub>	Output Low Voltage	NM25C04	I <sub>OL</sub> = 1.6 mA		0.4	V
		NM25C04E			0.4	V
		NM25C04M			0.4	V
V <sub>OH</sub>	Output High Voltage		I <sub>OH</sub> = 0.8 mA	V <sub>CC</sub> - 0.8		V
f <sub>OP</sub>	SCK Frequency	NM25C04			2.1	MHz
		NM25C04E			1	MHz
		NM25C04M			1	MHz
t <sub>RI</sub>	Input Rise Time				2.0	μs
t <sub>FI</sub>	Input Fall Time				2.0	μs
t <sub>CLH</sub>	Clock High Time	NM25C04	Note 2		190	ns
		NM25C04E			410	ns
		NM25C04M			410	ns
t <sub>CLL</sub>	Clock Low Time	NM25C04	Note 2		190	ns
		NM25C04E			410	ns
		NM25C04M			410	ns
t <sub>CSH</sub>	Min CS High Time	NM25C04	Note 3		240	ns
		NM25C04E			500	ns
		NM25C04M			500	ns
t <sub>CSS</sub>	CS Setup Time	NM25C04			240	ns
		NM25C04E			500	ns
		NM25C04M			500	ns
t <sub>DIS</sub>	Data Setup Time	NM25C04			100	ns
		NM25C04E			100	ns
		NM25C04M			100	ns

**DC and AC Electrical Characteristics**  $4.5V \leq V_{CC} \leq 5.5V$  (unless otherwise specified) (Continued)

Symbol	Parameter	Part Number	Conditions	Min	Max	Units
t <sub>HDS</sub>	HOLD Setup Time	NM25C04		90		ns
		NM25C04E		90		ns
		NM25C04M		90		ns
t <sub>CSN</sub>	CS Hold Time	NM25C04		240		ns
		NM25C04E		500		ns
		NM25C04M		500		ns
t <sub>DIN</sub>	Data Hold Time			100		ns
t <sub>HDN</sub>	HOLD Hold Time			90		ns
t <sub>PD</sub>	Output Delay	NM25C04	C <sub>L</sub> = 200 pF		240	ns
		NM25C04E			360	ns
		NM25C04M			360	ns
t <sub>LZ</sub>	HOLD to Output Low Z	NM25C04			100	ns
		NM25C04E			500	ns
		NM25C04M			500	ns
t <sub>DF</sub>	Output Disable Time	NM25C04	C <sub>L</sub> = 200 pF		240	ns
		NM25C04E			500	ns
		NM25C04M			500	ns
t <sub>HZ</sub>	HOLD to Output High Z	NM25C04			100	ns
		NM25C04E			500	ns
		NM25C04M			500	ns
t <sub>WP</sub>	Write Cycle Time		1-4 Bytes		5	ms

**Capacitance** (Note 4)

T<sub>A</sub> = 25°C, f = 1 MHz

Symbol	Test	Typ	Max	Units
C <sub>OUT</sub>	Output Capacitance	3	8	pF
C <sub>IN</sub>	Input Capacitance	2	6	pF

**AC Test Conditions**

Output Load	C <sub>L</sub> = 200 pF
Input Pulse Levels	0.8V to 3.5V
Timing Measurement Reference Level	
Input	1V and 2V
Output	0.8V and 2V

**Note 1:** Stress above those listed under "Absolute Maximum Ratings" may cause permanent damage to the device. This is a stress rating only and functional operation of the device at these or any other conditions above those indicated in the operational sections of the specification is not implied. Exposure to absolute maximum rating conditions for extended periods may affect device reliability.

**Note 2:** The SCK frequency specification specifies a minimum clock period of 476 ns; therefore, in an SCK clock cycle t<sub>CLH</sub> + t<sub>CLL</sub> must be greater than or equal to 476 ns. For example, if t<sub>CLL</sub> = 190 ns, then the minimum t<sub>CLH</sub> = 286 ns in order to meet the SCK frequency specification.

**Note 3:** CS must be brought high for a minimum of 240 ns (t<sub>CSH</sub>) between consecutive instruction cycles.

**Note 4:** This parameter is periodically sampled and not 100% tested.

Synchronous Data Timing

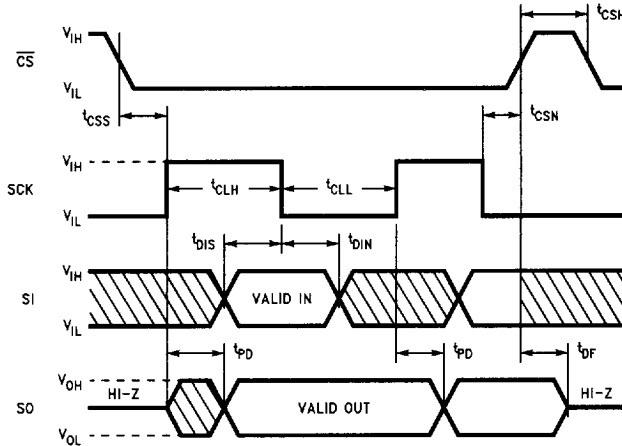

TL/D/11364-3

FIGURE 1. Timing Diagram

**Note:** When connected to the SPI port of a 68HC11 microcontroller, the NM25C04 accepts only a clock phase of 1 and a clock parity of 0.  
**Clock Phase 1:**  $\overline{CS}$  is held LOW during all serial communications and is held HIGH only between instructions.  
**Clock Polarity 0:** Clock data IN on negative clock edge and clock data OUT on positive clock edge.

SPI Serial Interface

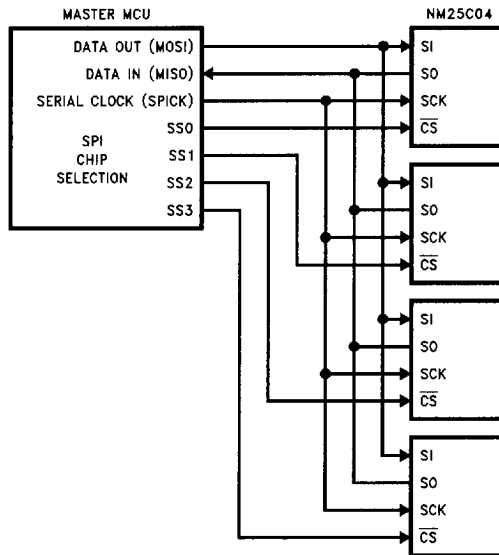

TL/D/11364-4

FIGURE 2

# Lexicon

This lexicon describes terms used in this serial interface description.

**MASTER:** The device that generates the serial clock is designated as the master. The NM25C04 can never function as a master.

**SLAVE:** The NM25C04 always operates as a slave as the serial clock pin is always an input.

**TRANSMITTER/RECEIVER:** The NM25C04 has separate pins for data transmission (SO) and reception (SI).

**MSB:** The Most Significant Bit is the first bit transmitted and received.

**CHIP SELECT:** The chip is selected when pin  $\overline{CS}$  is low. When the chip is *not* selected, data will not be accepted from pin SI, and the output pin SO is in high impedance.

**SERIAL OP-CODE:** The first byte transmitted after the chip is selected with  $\overline{CS}$  going low contains the op-code that defines the operation to be performed. In the READ and WRITE instructions the op-code also contains address bit A8.

**PROTOCOL:** When connected to the SPI port of a 68HC11 microcontroller, the NM25C04 accepts only a clock phase of 1 and a clock polarity of 0. The SPI protocol for this device defines the bytes transmitted on the SI and SO data lines for proper chip operation. See Figure 3.

brought low while the SCK pin is high. The device must remain selected during this sequence. To resume serial communication  $\overline{HOLD}$  is brought high while the SCK pin is high. Pins SI, SCK, and SO are at a high impedance state during HOLD. See Figure 4.

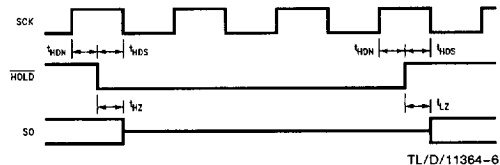

FIGURE 4.  $\overline{HOLD}$  Timing

**INVALID OP-CODE:** After an invalid code is received, no data is shifted into the NM25C04, and the SO data output pin remains high impedance until a new  $\overline{CS}$  falling edge re-initializes the serial communication. See Figure 5.

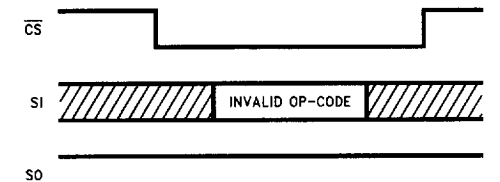

FIGURE 5

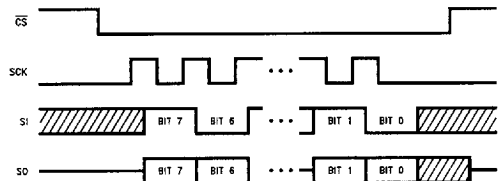

FIGURE 3

Phase 1:  $\overline{CS}$  is held LOW during all serial communications and is held HIGH only between instructions.

Polarity 0: Clock data IN on negative SCK edge and clock data OUT on positive SCK edge.

**HOLD:** The  $\overline{HOLD}$  pin is used in conjunction with the  $\overline{CS}$  to select the device. Once the device is selected and a serial sequence is underway,  $\overline{HOLD}$  may be forced low to suspend further serial communication with the device without resetting the serial sequence. Note that  $\overline{HOLD}$  must be

TABLE 1

Instruction Name	Instruction Format	Operation
WREN	0000 X110	Set Write Enable Latch
WRDI	0000 X100	Reset Write Enable Latch
RDSR	0000 X101	Read Status Register
WRSR	0000 X001	Write Status Register
READ	0000 A011	Read Data from Memory Array
WRITE	0000 A010	Write Data to Memory Array

Note: "A" represents MSB address bit A8.

**READ SEQUENCE: (One or More Bytes)**

Reading the memory via the SPI link requires the following sequence. The CS line is pulled low to select the device. The READ op-code (which includes A8) is transmitted on the SI line followed by the byte address (A7-A0) to be read. After this is done, data on the SI line becomes don't care. The data (D7-D0) at the address specified is then shifted out on the SO line. If only one byte is to be read, the CS line can be pulled back to the high level. It is possible to continue the READ sequence as the byte address is automatically incremented and data will continue to be shifted out. When the highest address is reached (1FF), the address counter rolls over to lowest address (000) allowing the entire memory to be read in one continuous READ cycle. See Figure 6.

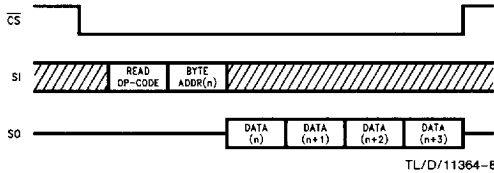

FIGURE 6

TL/D/11364-8

**READ STATUS REGISTER (RDSR):** The Read Status Register (RDSR) instruction provides access to the status register which is used to interrogate the READY/BUSY and WRITE ENABLE status of the chip. Two non-volatile status register bits are used to select one of four levels of BLOCK WRITE PROTECTION. The status register format is shown in Table 2.

TABLE 2. Status Register Format

Bit 7	Bit 6	Bit 5	Bit 4	Bit 3	Bit 2	Bit 1	Bit 0
1	1	1	1	BP1	BP0	WEN	RDY

Status register Bit 0 = 0 (RDY) indicates that the device is READY; Bit 0 = 1 indicates that a program cycle is in progress. Bit 1 = 0 (WEN) indicates that the device is not WRITE ENABLED; Bit 1 = 1 indicates that the device is WRITE ENABLED. Non-volatile status register Bits 2 and 3 (BP0 and BP1) indicate the level of BLOCK WRITE PROTECTION selected. The block write protection levels and corresponding status register control bits are shown in Table 3. Note that if a RDSR instruction is executed during a programming cycle only the RDY bit is valid. All other bits are 1s. See Figure 7.

TABLE 3. Block Write Protection Levels

Level	Status Register Bits		Array Addresses Protected
	BP1	BP0	
0	0	0	None
1	0	1	180-1FF
2	1	0	100-1FF
3	1	1	000-1FF

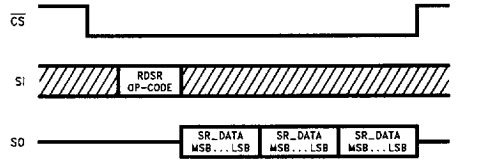

FIGURE 7

TL/D/11364-9

**WRITE ENABLE (WREN):** When V<sub>CC</sub> is applied to the chip, it "powers up" in the write disable state. Therefore, all programming modes must be preceded by a WRITE ENABLE (WREN) instruction. Additionally the WP pin must be held high during a WRITE ENABLE instruction. At the completion of a WRITE or WRSR cycle the device is automatically returned to the write disable state. Note that a WRITE DISABLE (WRDI) instruction or forcing the WP pin low will also return the device to the write disable state. See Figure 8.

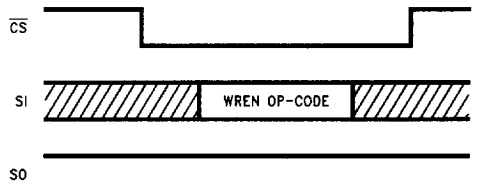

FIGURE 8

TL/D/11364-10

**WRITE DISABLE (WRDI):** To protect against accidental data disturbance the WRITE DISABLE (WRDI) instruction disables all programming modes. The WRITE DISABLE instruction is independent of the status of the WP pin. See Figure 9.

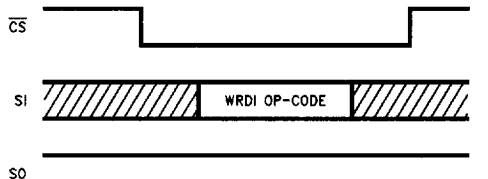

FIGURE 9

TL/D/11364-11

**WRITE SEQUENCE:** To program the device the WRITE PROTECT ( $\overline{WP}$ ) pin must be held high and two separate instructions must be executed. The chip *must first be write enabled* via the WRITE ENABLE instruction and then a WRITE instruction must be executed. Moreover, the address of the memory location(s) to be programmed must be outside the protected address field selected by the Block Write Protection Level. See Table 3.

A WRITE command requires the following sequence. The  $\overline{CS}$  line is pulled low to select the device, then the WRITE op-code (which includes A8) is transmitted on the SI line followed by the byte address (A7–A0) and the corresponding data (D7–D0) to be programmed. Programming will start after the  $\overline{CS}$  pin is forced back to a high level. Note that the LOW to HIGH transition of the  $\overline{CS}$  pin must occur during the SCK low time immediately after clocking in the D0 data bit. See Figure 10. The READY/BUSY status of the device can be determined by executing a READ STATUS REGISTER

(RDSR) instruction. Bit 0 = 1 indicates that the WRITE cycle is still in progress and Bit 0 = 0 indicates that the WRITE cycle has ended. During the WRITE programming cycle (Bit 0 = 1) only the READ STATUS REGISTER instruction is enabled.

The NM25C04 is capable of a four byte PAGE WRITE operation. After receipt of each byte of data the two low order address bits are internally incremented by one. The seven high order bits of the address will remain constant. If the master should transmit more than four bytes of data, the address counter will "roll over", and the previously loaded data will be reloaded.

At the completion of a WRITE cycle the device is automatically returned to the write disable state.

If the  $\overline{WP}$  pin is forced low or the device is not WRITE enabled, the device will ignore the WRITE instruction and return to the standby state when  $\overline{CS}$  is forced high. A new  $\overline{CS}$  falling edge is required to re-initialize the serial communication. See Figure 11.

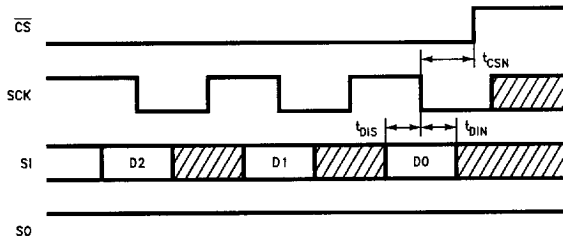

FIGURE 10. Start WRITE Condition

TL/D/11364-13

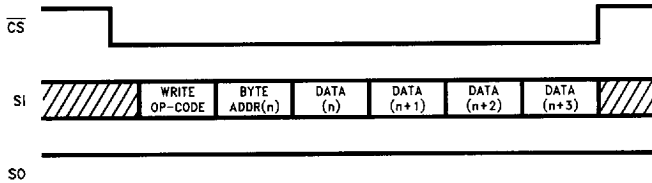

FIGURE 11

TL/D/11364-12

**WRITE STATUS REGISTER (WRSR):** The WRITE STATUS REGISTER (WRSR) instruction is used to program the non-volatile status register Bits 2 and 3 (BP0 and BP1). As in the WRITE mode the WRITE PROTECT ( $\overline{WP}$ ) pin must be held high and two separate instructions must be executed. The chip must first be write enabled via the WRITE ENABLE instruction and then a WRSR instruction must be executed.

The WRSR command requires the following sequence. The  $\overline{CS}$  line is pulled low to select the device and then the WRSR op-code is transmitted on the SI line followed by the data to be programmed (see Figure 12). Note that the first four bits are don't care bits followed by BP1 and BP0 then

two additional don't care bits. Programming will start after the  $\overline{CS}$  pin is forced back to a high level. As in the WRITE instruction the LOW to HIGH transition of the  $\overline{CS}$  pin must occur during the SCK low time immediately after clocking in the last don't care bit. See Figure 13.

The READY/BUSY status of the device can be determined by executing a READ STATUS REGISTER (RDSR) instruction. Bit 0 = 1 indicates that the WRSR cycle is still in progress and Bit 0 = 0 indicates that the WRSR cycle has ended.

At the completion of a WRSR cycle the device is automatically returned to the write disable state.

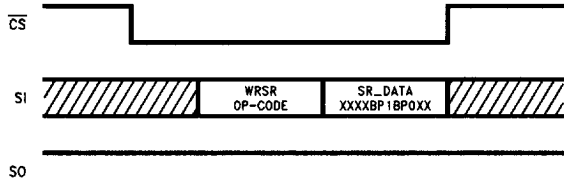

FIGURE 12

TL/D/11364-14

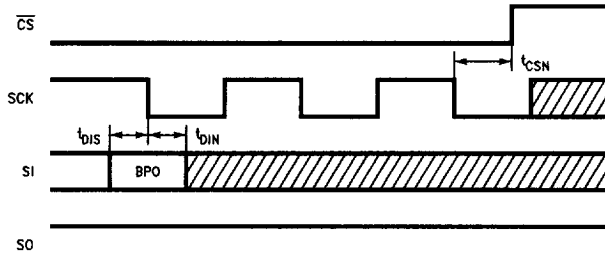

FIGURE 13. Start WRSR Condition

TL/D/11364-15