



Advance Information

16K

X28HC16

2K x 8 Bit

5 Volt, Byte Alterable E<sup>2</sup>PROM

T-46-13-27

FEATURES

- 55 ns Access Time
- SIMPLE Byte and Page Write
  - Single 5 Volt Supply
  - No External High Voltages or V<sub>PP</sub> Control Circuits
  - Self Timed
  - No Erase Before Write
  - No Complex Programming Algorithms
  - No Overerase Problem
- Low Power CMOS
  - 40 mA Active Current Max.
  - 200 μA Standby Current Max.
- Fast Write Cycle Times
  - 64-Byte Page Write Operation
  - Byte or Page Write Cycle: 2 ms Typical
  - Complete Memory Rewrite: 0.1 Sec. Typical
  - Effective Byte Write Cycle Time: 32 μs Typical
- Software Data Protection
- End of Write Detection
  - DATA Polling
  - Toggle Bit
- High Reliability
  - Endurance: 10,000 Cycles
  - Data Retention: 100 Years
- JEDEC Approved Byte-Wide Pinout

DESCRIPTION

The X28HC16 is an 2K x 8 E<sup>2</sup>PROM, fabricated with Xicor's proprietary, high performance, floating gate CMOS technology. Like all Xicor programmable non-volatile memories the X28HC16 is a 5V only device. The X28HC16 features the JEDEC approved pinout for byte-wide memories, compatible with industry standard RAMs.

The X28HC16 supports a 64-byte page write operation, effectively providing a 32 μs/byte write cycle and enabling the entire memory to be typically written in 0.1 seconds. The X28HC16 also features DATA Polling and Toggle Bit Polling, two methods providing early end of write detection. In addition, the X28HC16 includes a user-optional software data protection mode that further enhances Xicor's hardware write protect capability.

Xicor E<sup>2</sup>PROMs are designed and tested for applications requiring extended endurance. Inherent data retention is greater than 100 years.

3

PIN CONFIGURATION

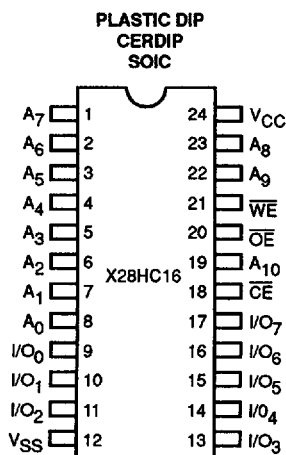

3861 FHD F02

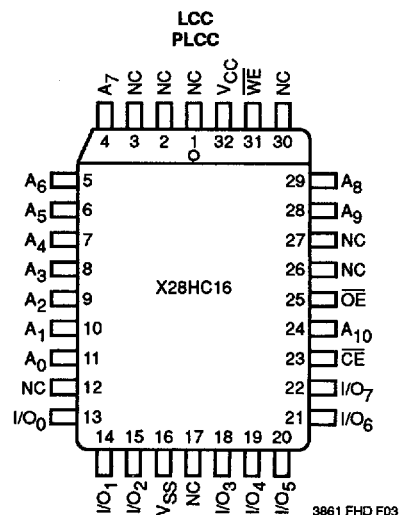

3861 FHD F03

## X28HC16

### PIN DESCRIPTIONS

#### Addresses ( $A_0$ – $A_{10}$ )

The Address inputs select an 8-bit memory location during a read or write operation.

#### Chip Enable ( $\overline{CE}$ )

The Chip Enable input must be LOW to enable all read/write operations. When  $\overline{CE}$  is HIGH, power consumption is reduced.

#### Output Enable ( $\overline{OE}$ )

The Output Enable input controls the data output buffers and is used to initiate read operations.

#### Data In/Data Out ( $I/O_0$ – $I/O_7$ )

Data is written to or read from the X28HC16 through the I/O pins.

#### Write Enable ( $\overline{WE}$ )

The Write Enable input controls the writing of data to the X28HC16.

### PIN NAMES

Symbol	Description
$A_0$ – $A_{10}$	Address Inputs
$I/O_0$ – $I/O_7$	Data Input/Output
$\overline{WE}$	Write Enable
$\overline{CE}$	Chip Enable
$\overline{OE}$	Output Enable
$V_{CC}$	+5V
$V_{SS}$	Ground
NC	No Connect

3861 PGM T01

### FUNCTIONAL DIAGRAM

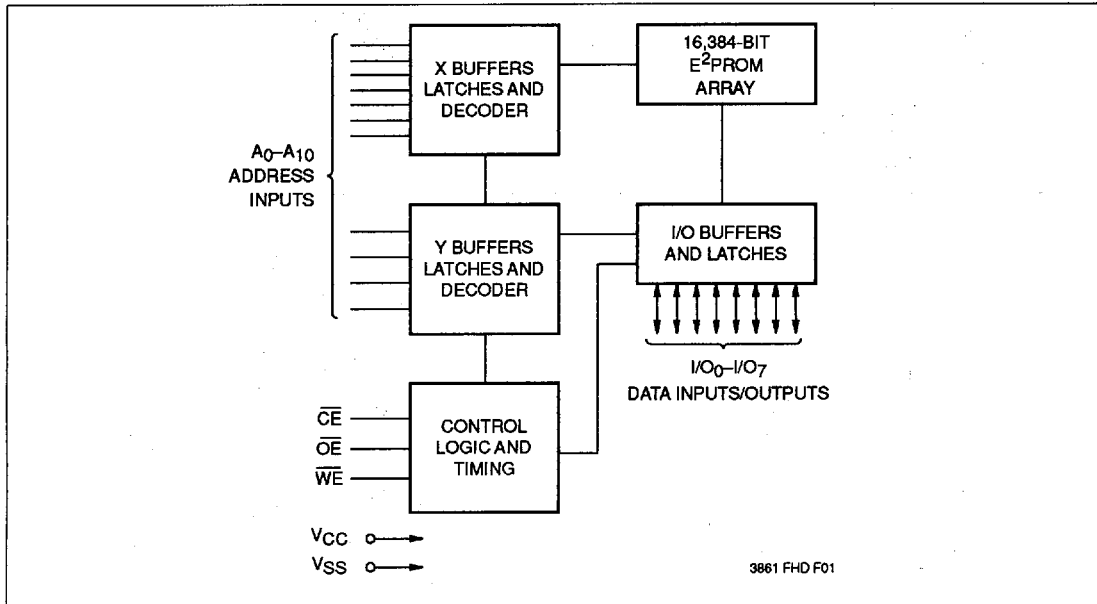

## X28HC16

### DEVICE OPERATION

#### Read

Read operations are initiated by both  $\overline{OE}$  and  $\overline{CE}$  LOW. The read operation is terminated by either  $\overline{CE}$  or  $\overline{OE}$  returning HIGH. This 2-line control architecture eliminates bus contention in a system environment. The data bus will be in a high impedance state when either  $\overline{OE}$  or  $\overline{CE}$  is HIGH.

#### Write

Write operations are initiated when both  $\overline{CE}$  and  $\overline{WE}$  are LOW and  $\overline{OE}$  is HIGH. The X28HC16 supports both a  $\overline{CE}$  and  $\overline{WE}$  controlled write cycle. That is, the address is latched by the falling edge of either  $\overline{CE}$  or  $\overline{WE}$ , whichever occurs last. Similarly, the data is latched internally by the rising edge of either  $\overline{CE}$  or  $\overline{WE}$ , whichever occurs first. A byte write operation, once initiated, will automatically continue to completion, typically within 2 ms.

#### Page Write Operation

The page write feature of the X28HC16 allows the entire memory to be written in 0.25 seconds. Page write allows two to sixty-four bytes of data to be consecutively written to the X28HC16 prior to the commencement of the internal programming cycle. The host can fetch data from another location within the system during a page write operation (change the source address), but the page address ( $A_6$  through  $A_{10}$ ) for each subsequent valid write cycle to the part during this operation must be the same as the initial page address.

The page write mode can be initiated during any write operation. Following the initial byte write cycle, the host can write an additional one to sixty-three bytes in the same manner as the first byte was written. Each successive byte load cycle, started by the  $\overline{WE}$  HIGH to LOW transition, must begin within 100  $\mu$ s of the falling edge of the preceding  $\overline{WE}$ . If a subsequent  $\overline{WE}$  HIGH to LOW transition is not detected within 100  $\mu$ s, the internal automatic programming cycle will commence. There is no page write window limitation. Effectively the page

write window is infinitely wide, so long as the host continues to access the device within the byte load cycle time of 100  $\mu$ s.

#### Write Operation Status Bits

The X28HC16 provides the user two write operation status bits. These can be used to optimize a system write cycle time. The status bits are mapped onto the I/O bus as shown in Figure 1.

Figure 1. Status Bit Assignment

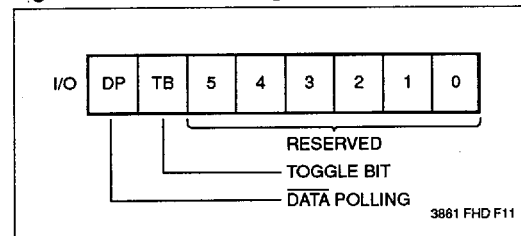

3

#### DATA Polling (I/O<sub>7</sub>)

The X28HC16 features  $\overline{DATA}$  Polling as a method to indicate to the host system that the byte write or page write cycle has completed.  $\overline{DATA}$  Polling allows a simple bit test operation to determine the status of the X28HC16, eliminating additional interrupt inputs or external hardware. During the internal programming cycle, any attempt to read the last byte written will produce the complement of that data on I/O<sub>7</sub> (i.e. write data = 0xxx xxxx, read data = 1xxx xxxx). Once the programming cycle is complete, I/O<sub>7</sub> will reflect true data.

#### Toggle Bit (I/O<sub>6</sub>)

The X28HC16 also provides another method for determining when the internal write cycle is complete. During the internal programming cycle I/O<sub>6</sub> will toggle from one to zero and zero to one on subsequent attempts to read the device. When the internal cycle is complete the toggling will cease and the device will be accessible for additional read or write operations.

**X28HC16**

**DATA POLLING I/O,  
Figure 2. DATA Polling Bus Sequence**

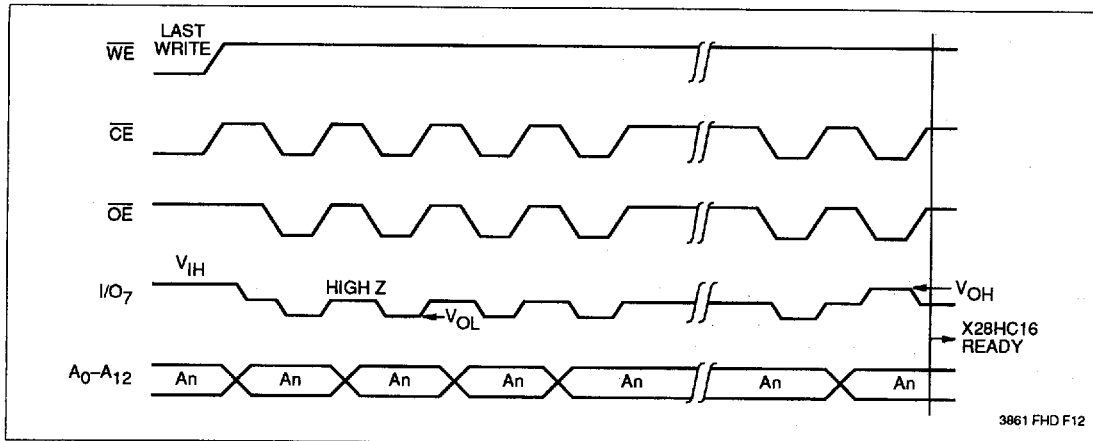

**Figure 3. DATA Polling Software Flow**

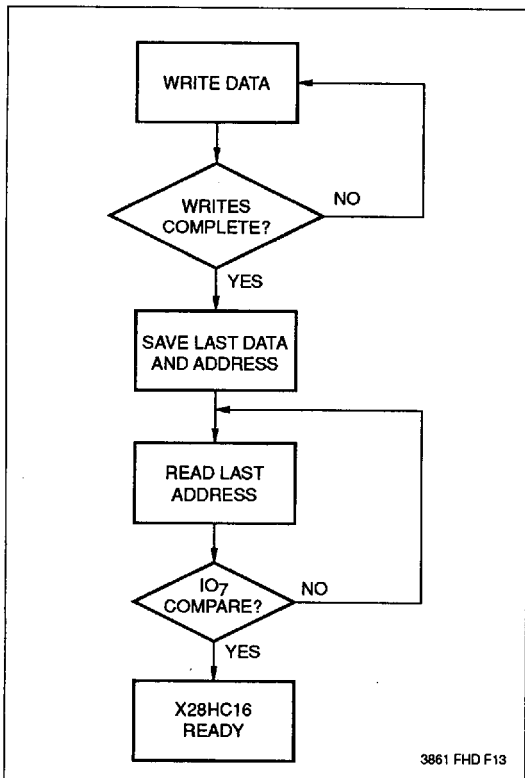

DATA Polling can effectively reduce the time for writing to the X28HC16. The timing diagram in Figure 2 illustrates the sequence of events on the bus. The software flow diagram in Figure 3 illustrates one method of implementing the routine.

**X28HC16**

**THE TOGGLE BIT I/O,  
Figure 4. Toggle Bit Bus Sequence**

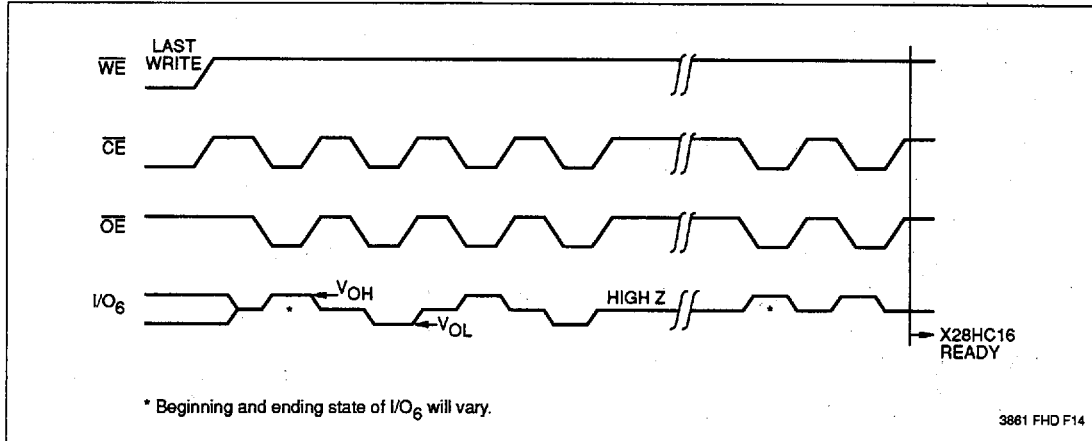

**3**

**Figure 5. Toggle Bit Software Flow**

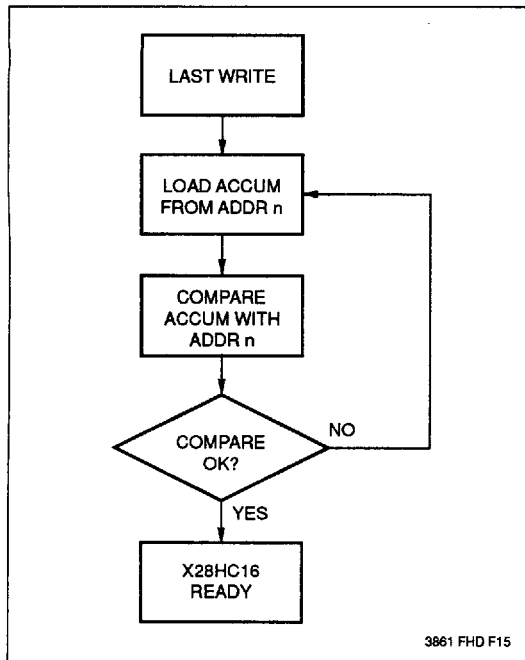

The Toggle Bit can eliminate the software housekeeping chore of saving and fetching the last address and data written to a device in order to implement DATA Polling. This can be especially helpful in an array comprised of multiple X28HC16 memories that is frequently updated. Toggle Bit testing can also provide a method for status checking in multiprocessor applications. The timing diagram in Figure 4 illustrates the sequence of events on the bus. The software flow diagram in Figure 5 illustrates a method for testing the Toggle Bit.

## X28HC16

---

### HARDWARE DATA PROTECTION

The X28HC16 provides two hardware features that protect nonvolatile data from inadvertent writes.

- Default V<sub>CC</sub> Sense—All write functions are inhibited when V<sub>CC</sub> is  $\leq 3V$  typically.
- Write Inhibit—Holding either  $\overline{OE}$  LOW,  $\overline{WE}$  HIGH, or  $\overline{CE}$  HIGH will prevent an inadvertent write cycle during power-on and power-off, maintaining data integrity.

### SOFTWARE DATA PROTECTION

The X28HC16 offers a software controlled data protection feature. The X28HC16 is shipped from Xicor with the software data protection NOT ENABLED; that is, the device will be in the standard operating mode. In this mode data should be protected during power-up/-down operations through the use of external circuits. The host would then have open read and write access of the device once V<sub>CC</sub> was stable.

The X28HC16 can be automatically protected during power-up and power-down without the need for external circuits by employing the software data protection fea-

ture. The internal software data protection circuit is enabled after the first write operation utilizing the software algorithm. This circuit is nonvolatile and will remain set for the life of the device unless the reset command is issued.

Once the software protection is enabled, the X28HC16 is also protected from inadvertent and accidental writes in the powered-on state. That is, the software algorithm must be issued prior to writing additional data to the device.

### SOFTWARE ALGORITHM

Selecting the software data protection mode requires the host system to precede data write operations by a series of three write operations to three specific addresses. Refer to Figure 6 and 7 for the sequence. The three byte sequence opens the page write window enabling the host to write from one to sixty-four bytes of data. Once the page load cycle has been completed, the device will automatically be returned to the data protected state.

**X28HC16**

**Figure 6. Timing Sequence for Software Data Protection —  
Byte or Page Write**

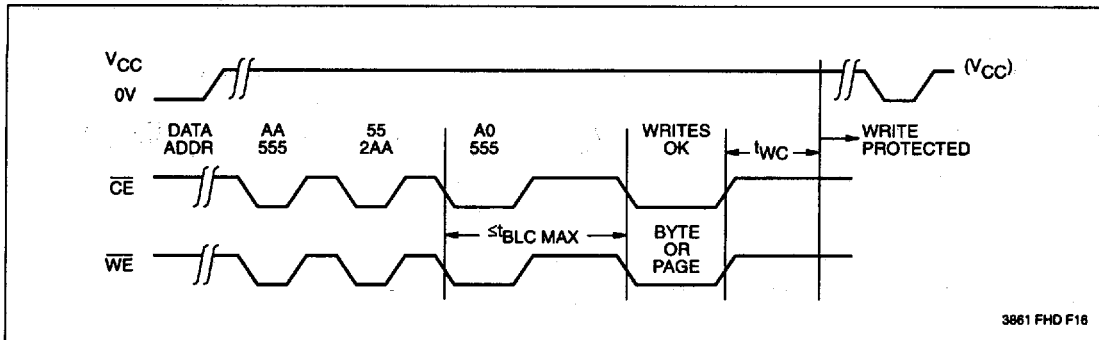

3

**Figure 7. Write Sequence for  
Software Data Protection**

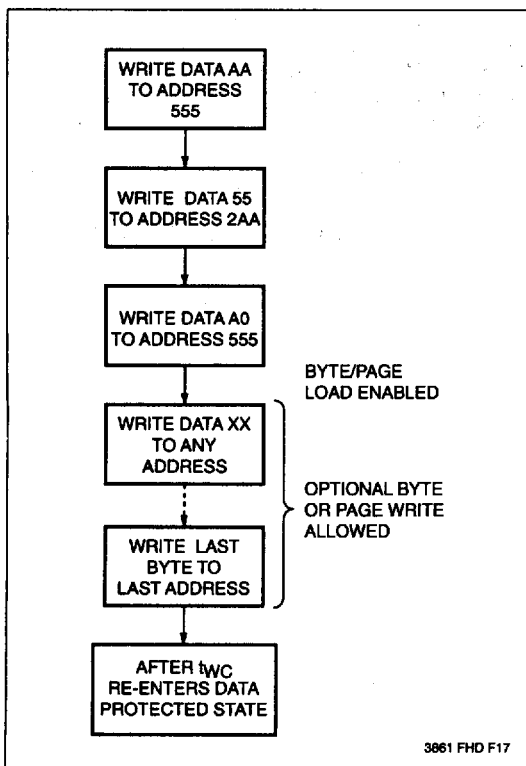

Regardless of whether the device has previously been protected or not, once the software data protection algorithm is used, the X28HC16 will automatically disable further writes unless another command is issued to deactivate it. If no further commands are issued the X28HC16 will be write protected during power-down and after any subsequent power-up.

*Note: Once initiated, the sequence of write operations should not be interrupted.*

**X28HC16**

**RESETTING SOFTWARE DATA PROTECTION**

**Figure 8. Reset Software Data Protection Timing Sequence**

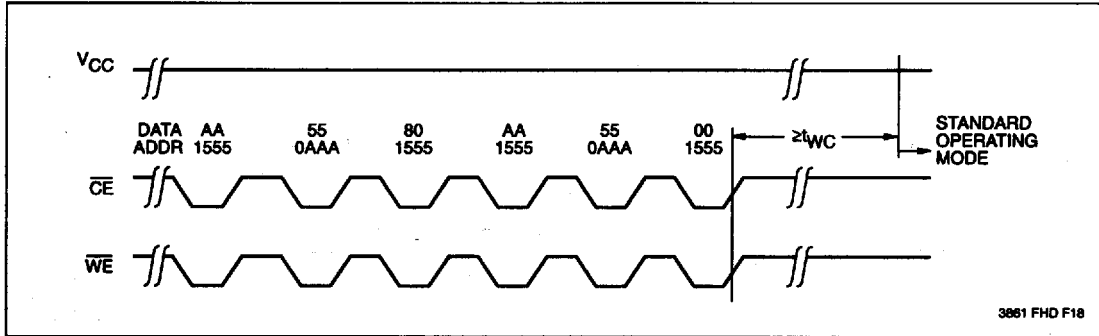

**Figure 9. Software Sequence to Deactivate Software Data Protection**

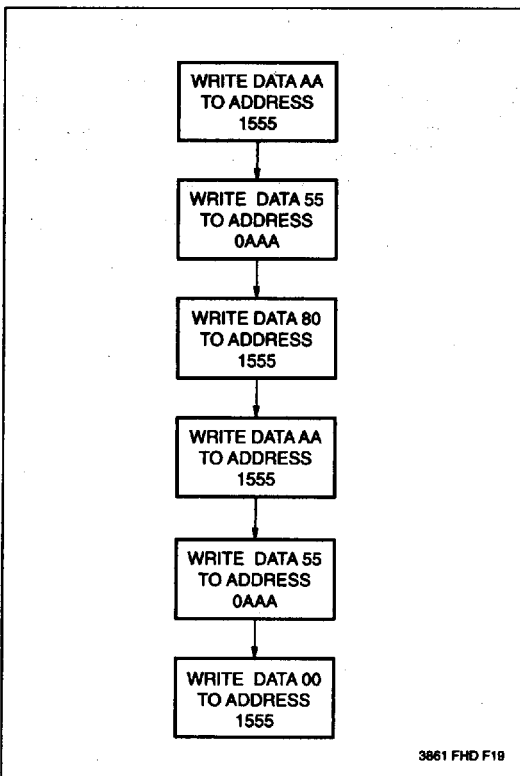

In the event the user wants to deactivate the software data protection feature for testing or reprogramming in an E<sup>2</sup>PROM programmer, the following six step algorithm will reset the internal protection circuit. After  $t_{WC}$ , the X28HC16 will be in standard operating mode.

*Note: Once initiated, the sequence of write operations should not be interrupted.*

*It should also be noted, the Reset SDP operation performs a device "program" operation; whereby all bytes are written to 00[H].*

## X28HC16

---

### SYSTEM CONSIDERATIONS

Because the X28HC16 is frequently used in large memory arrays it is provided with a two line control architecture for both read and write operations. Proper usage can provide the lowest possible power dissipation and eliminate the possibility of contention where multiple I/O pins share the same bus.

To gain the most benefit it is recommended that  $\overline{CE}$  be decoded from the address bus and be used as the primary device selection input. Both  $\overline{OE}$  and  $\overline{WE}$  would then be common among all devices in the array. For a read operation this assures that all deselected devices are in their standby mode and that only the selected device(s) is outputting data on the bus.

Because the X28HC16 has two power modes, standby and active, proper decoupling of the memory array is of

prime concern. Enabling  $\overline{CE}$  will cause transient current spikes. The magnitude of these spikes is dependent on the output capacitive loading of the I/Os. Therefore, the larger the array sharing a common bus, the larger the transient spikes. The voltage peaks associated with the current transients can be suppressed by the proper selection and placement of decoupling capacitors. As a minimum, it is recommended that a 0.1  $\mu\text{F}$  high frequency ceramic capacitor be used between  $V_{CC}$  and GND at each device. Depending on the size of the array, the value of the capacitor may have to be larger.

In addition, it is recommended that a 4.7  $\mu\text{F}$  electrolytic bulk capacitor be placed between  $V_{CC}$  and GND for each eight devices employed in the array. This bulk capacitor is employed to overcome the voltage droop caused by the inductive effects of the PC board traces.

**X28HC16**

**ABSOLUTE MAXIMUM RATINGS\***

Temperature Under Bias  
 X28HC16 ..... -10°C to +85°C  
 X28HC16I, X28HC16M ..... -65°C to +135°C  
 Storage Temperature ..... -65°C to +150°C  
 Voltage on any Pin with  
 Respect to Ground ..... -1.0V to +7.0V  
 D.C. Output Current ..... 5 mA  
 Lead Temperature  
 (Soldering, 10 Seconds) ..... 300°C

**\*COMMENT**

Stresses above those listed under "Absolute Maximum Ratings" may cause permanent damage to the device. This is a stress rating only and the functional operation of the device at these or any other conditions above those indicated in the operational sections of this specification is not implied. Exposure to absolute maximum rating conditions for extended periods may affect device reliability.

**RECOMMENDED OPERATING CONDITIONS**

Temperature	Min.	Max.
Commercial	0°C	70°C
Industrial	-40°C	+85°C
Military	-55°C	+125°C

3861 PGM T02

Supply Voltage	Limits
X28HC16	5V ± 10%

3861 PGM T03

**D.C. OPERATING CHARACTERISTICS** (Over recommended operating conditions unless otherwise specified.)

Symbol	Parameter	Limits			Units	Test Conditions
		Min.	Typ.(1)	Max.		
I <sub>CC</sub>	V <sub>CC</sub> Current (Active) (TTL Inputs)		15	40	mA	$\overline{CE} = \overline{OE} = V_{IL}$ , $\overline{WE} = V_{IH}$ , All I/O's = Open, Address Inputs = TTL Levels @ f = 10 MHz
I <sub>SB1</sub>	V <sub>CC</sub> Current (Standby) (TTL Inputs)		1	2	mA	$\overline{CE} = V_{IH}$ , $\overline{OE} = V_{IL}$ All I/O's = Open, Other Inputs = V <sub>IH</sub>
I <sub>SB2</sub>	V <sub>CC</sub> Current (Standby) (CMOS Inputs)		100	200	µA	$\overline{CE} = V_{CC} - 0.3V$ , $\overline{OE} = GND$ All I/O's = Open, Other Inputs = V <sub>CC</sub> - 0.3V
I <sub>LI</sub>	Input Leakage Current			±10	µA	V <sub>IN</sub> = GND to V <sub>CC</sub>
I <sub>LO</sub>	Output Leakage Current			±10	µA	V <sub>OUT</sub> = GND to V <sub>CC</sub> , $\overline{CE} = V_{IH}$
V <sub>IL</sub> (2)	Input Low Voltage	-1.0		0.8	V	
V <sub>IH</sub> (2)	Input High Voltage	2.0		V <sub>CC</sub> + 1.0	V	
V <sub>OL</sub>	Output Low Voltage			0.4	V	I <sub>OL</sub> = 5 mA
V <sub>OH</sub>	Output High Voltage	2.4			V	I <sub>OH</sub> = -5 mA

3861 PGM T04

Notes: (1) Typical values are for T<sub>A</sub> = 25°C and nominal supply voltage  
 (2) V<sub>IL</sub> min. and V<sub>IH</sub> max. are for reference only and are not tested.

**X28HC16**

**ENDURANCE AND DATA RETENTION**

Parameter	Min.	Max.	Unit
Minimum Endurance	10,000		Cycles/Byte
Data Retention	100		Years

3861 PGM T05

**POWER-UP TIMING**

Symbol	Parameter	Typ. (1)	Units
t <sub>PUR</sub> <sup>(3)</sup>	Power-up to Read Operation	100	μs
t <sub>PWW</sub> <sup>(3)</sup>	Power-up to Write Operation	5	ms

3861 PGM T06

**CAPACITANCE** T<sub>A</sub> = 25°C, f = 1.0 MHz, V<sub>CC</sub> = 5V

Symbol	Parameter	Max.	Units	Test Conditions
C <sub>I/O</sub> <sup>(3)</sup>	Input/Output Capacitance	10	pF	V <sub>I/O</sub> = 0V
C <sub>IN</sub> <sup>(3)</sup>	Input Capacitance	6	pF	V <sub>IN</sub> = 0V

3861 PGM T07

**A.C. CONDITIONS OF TEST**

Input Pulse Levels	0V to 3.0V
Input Rise and Fall Times	5 ns
Input and Output Timing Levels	1.5V

3861 PGM T08

**MODE SELECTION**

$\overline{CE}$	$\overline{OE}$	$\overline{WE}$	Mode	I/O	Power
L	L	H	Read	D <sub>OUT</sub>	Active
L	H	L	Write	D <sub>IN</sub>	Active
H	X	X	Standby and Write Inhibit	High Z	Standby
X	L	X	Write Inhibit	—	—
X	X	H	Write Inhibit	—	—

3861 PGM T09

**EQUIVALENT A.C. LOAD CIRCUITS**

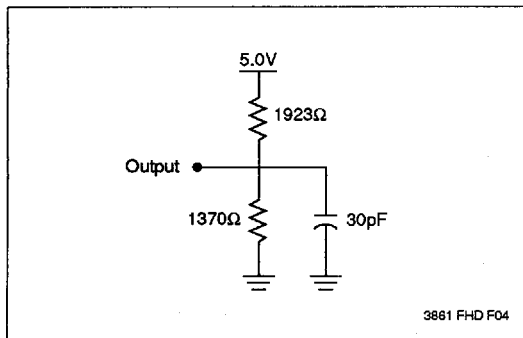

3861 FHD F04

**Note:** (3) This parameter is periodically sampled and not 100% tested.

**SYMBOL TABLE**

WAVEFORM	INPUTS	OUTPUTS
	Must be steady	Will be steady
	May change from Low to High	Will change from Low to High
	May change from High to Low	Will change from High to Low
	Don't Care: Changes Allowed	Changing: State Not Known
	N/A	Center Line is High Impedance

## X28HC16

A.C. CHARACTERISTICS (Over the recommended operating conditions unless otherwise specified.)

### Read Cycle Limits

Symbol	Parameter	X28HC16-55		X28HC16-70		X28HC16-90		X28HC16-12		Units
		Min.	Max.	Min.	Max.	Min.	Max.	Min.	Max.	
$t_{RC}$	Read Cycle Time	55		70		90		120		ns
$t_{CE}$	Chip Enable Access Time		55		70		90		120	ns
$t_{AA}$	Address Access Time		55		70		90		120	ns
$t_{OE}$	Output Enable Access Time		30		35		40		50	ns
$t_{LZ}^{(4)}$	CE Low to Active Output	0		0		0		0		ns
$t_{OLZ}^{(4)}$	OE Low to Active Output	0		0		0		0		ns
$t_{HZ}^{(4)}$	CE High to High Z Output		30	0	30		30		30	ns
$t_{OHZ}^{(4)}$	OE High to High Z Output		30	0	30		30		30	ns
$t_{OH}$	Output Hold from Address Change	0		0		0		0		ns

3858 PGM T10

### Read Cycle

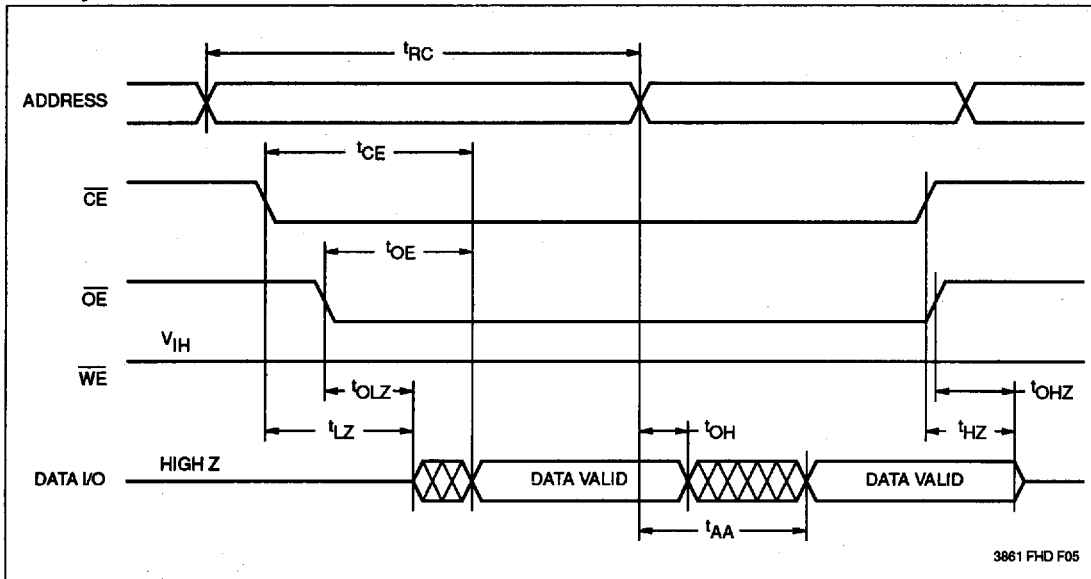

3861 FHD F05

Notes: (4)  $t_{LZ}$  min.,  $t_{HZ}$ ,  $t_{OLZ}$  min., and  $t_{OHZ}$  are periodically sampled and not 100%.  $t_{HZ}$  max. and  $t_{OHZ}$  max. are measured from the point when CE or OE return high (whichever occurs first) to the time when the outputs are no longer driven.

**X28HC16**

**WRITE CYCLE LIMITS**

Symbol	Parameter	Min.	Typ.(1)	Max.	Units
$t_{WC}^{(5)}$	Write Cycle Time		2	5	ms
$t_{AS}$	Address Setup Time	0			ns
$t_{AH}$	Address Hold Time	50			ns
$t_{CS}$	Write Setup Time	0			ns
$t_{CH}$	Write Hold Time	0			ns
$t_{CW}$	CE Pulse Width	50			ns
$t_{OES}$	OE High Setup Time	0			ns
$t_{OEH}$	OE High Hold Time	0			ns
$t_{WP}$	WE Pulse Width	50			ns
$t_{WPH}^{(6)}$	WE High Recovery	50			ns
$t_{DV}^{(6)}$	Data Valid			1	$\mu$ s
$t_{DS}$	Data Setup	50			ns
$t_{DH}$	Data Hold	0			ns
$t_{DW}^{(6)}$	Delay to Next Write	10			$\mu$ s
$t_{BLC}$	Byte Load Cycle	0.150		100	$\mu$ s

3861 PGM T11

**3**

**WE Controlled Write Cycle**

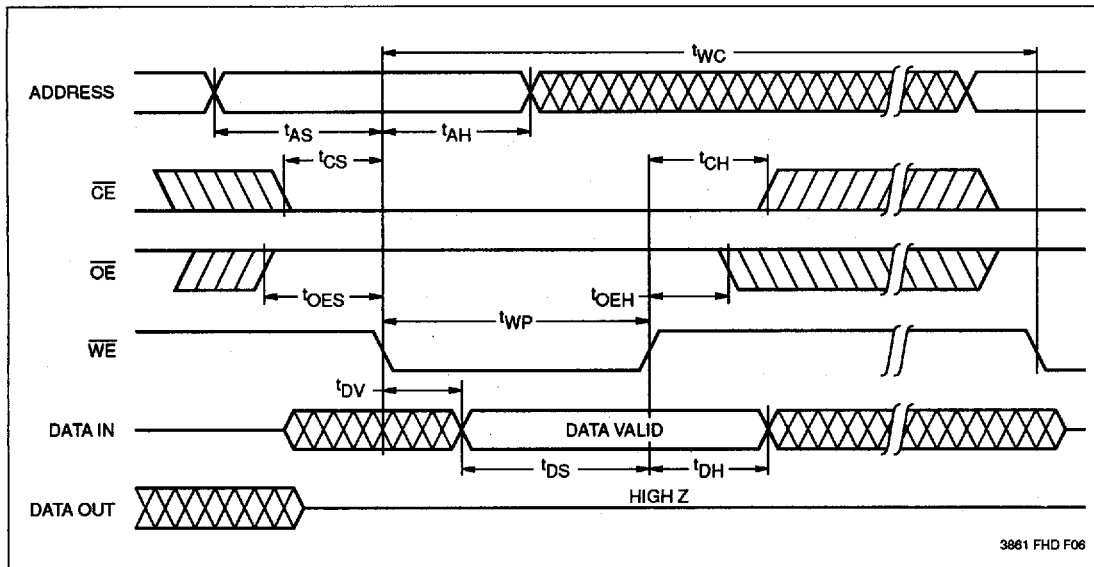

3861 FHD P06

**Notes:** (5)  $t_{WC}$  is the minimum cycle time to be allowed from the system perspective unless polling techniques are used. It is the maximum time the device requires to automatically complete the internal write operation.  
 (6)  $t_{WPH}$  and  $t_{DW}$  are periodically sampled and not 100% tested.

**X28HC16**

**$\overline{CE}$  Controlled Write Cycle**

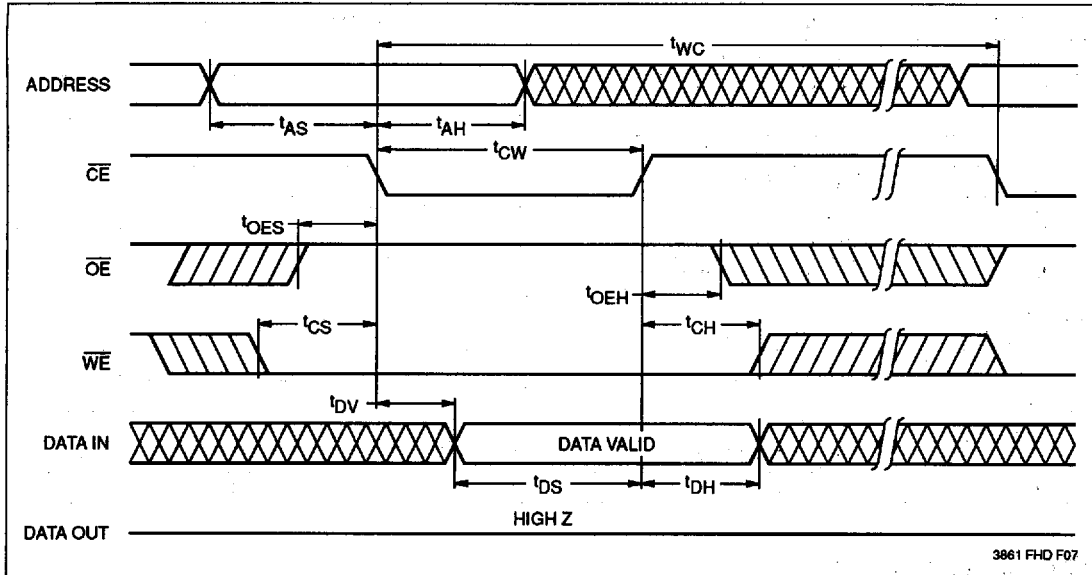

**Page Write Cycle**

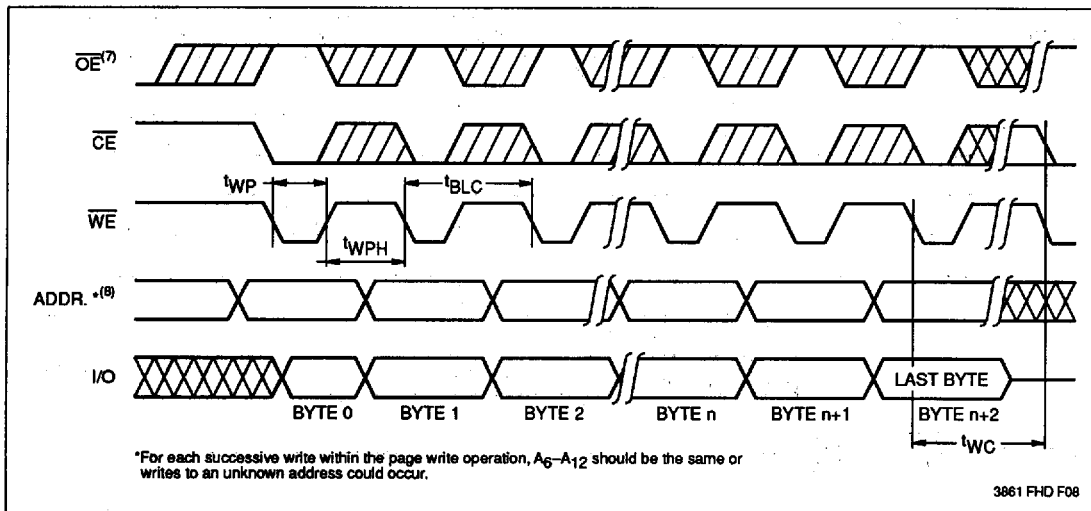

- Notes:** (7) Between successive byte writes within a page write operation,  $\overline{OE}$  can be strobed LOW: e.g. this can be done with  $\overline{CE}$  and  $\overline{WE}$  HIGH to fetch data from another memory device within the system for the next write; or with  $\overline{WE}$  HIGH and  $\overline{CE}$  LOW effectively performing a polling operation.
- (8) The timings shown above are unique to page write operations. Individual byte load operations within the page write must conform to either the  $\overline{CE}$  or  $\overline{WE}$  controlled write cycle timing.

**X28HC16**

**DATA Polling Timing Diagram<sup>(9)</sup>**

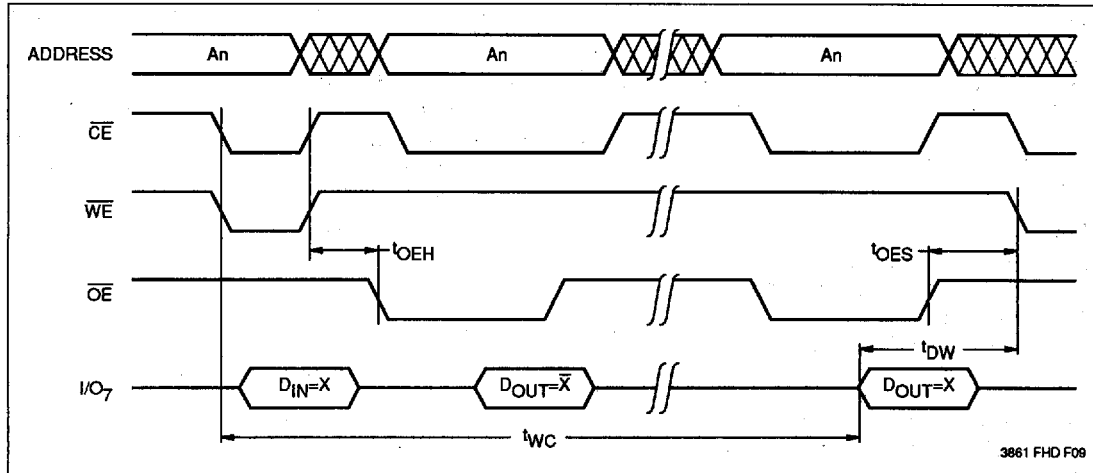

3

**Toggle Bit Timing Diagram<sup>(9)</sup>**

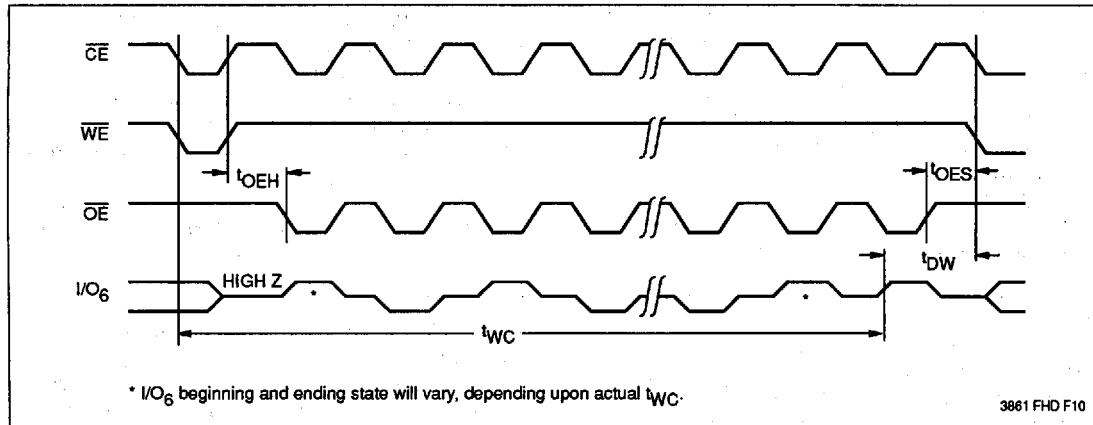

\* I/O<sub>6</sub> beginning and ending state will vary, depending upon actual  $t_{WC}$ .

**Note:** (9) Polling operations are by definition read cycles and are therefore subject to read cycle timings.

## X28HC16

### DEVICE OPERATION

#### Read

Read operations are initiated by both  $\overline{OE}$  and  $\overline{CE}$  LOW. The read operation is terminated by either  $\overline{CE}$  or  $\overline{OE}$  returning HIGH. This 2-line control architecture eliminates bus contention in a system environment. The data bus will be in a high impedance state when either  $\overline{OE}$  or  $\overline{CE}$  is HIGH.

#### Write

Write operations are initiated when both  $\overline{CE}$  and  $\overline{WE}$  are LOW and  $\overline{OE}$  is HIGH. The X28HC16 supports both a  $\overline{CE}$  and  $\overline{WE}$  controlled write cycle. That is, the address is latched by the falling edge of either  $\overline{CE}$  or  $\overline{WE}$ , whichever occurs last. Similarly, the data is latched internally by the rising edge of either  $\overline{CE}$  or  $\overline{WE}$ , whichever occurs first. A byte write operation, once initiated, will automatically continue to completion, typically within 2 ms.

#### Page Write Operation

The page write feature of the X28HC16 allows the entire memory to be written in 0.25 seconds. Page write allows two to sixty-four bytes of data to be consecutively written to the X28HC16 prior to the commencement of the internal programming cycle. The host can fetch data from another location within the system during a page write operation (change the source address), but the page address ( $A_6$  through  $A_{10}$ ) for each subsequent valid write cycle to the part during this operation must be the same as the initial page address.

The page write mode can be initiated during any write operation. Following the initial byte write cycle, the host can write an additional one to sixty-three bytes in the same manner as the first byte was written. Each successive byte load cycle, started by the  $\overline{WE}$  HIGH to LOW transition, must begin within 100  $\mu$ s of the falling edge of the preceding  $\overline{WE}$ . If a subsequent  $\overline{WE}$  HIGH to LOW transition is not detected within 100  $\mu$ s, the internal automatic programming cycle will commence. There is no page write window limitation. Effectively the page

write window is infinitely wide, so long as the host continues to access the device within the byte load cycle time of 100  $\mu$ s.

#### Write Operation Status Bits

The X28HC16 provides the user two write operation status bits. These can be used to optimize a system write cycle time. The status bits are mapped onto the I/O bus as shown in Figure 1.

Figure 1. Status Bit Assignment

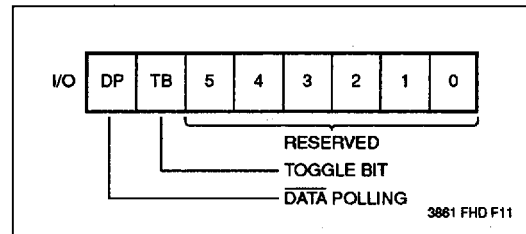

#### DATA Polling ( $I/O_7$ )

The X28HC16 features  $\overline{DATA}$  Polling as a method to indicate to the host system that the byte write or page write cycle has completed.  $\overline{DATA}$  Polling allows a simple bit test operation to determine the status of the X28HC16, eliminating additional interrupt inputs or external hardware. During the internal programming cycle, any attempt to read the last byte written will produce the complement of that data on  $I/O_7$  (i.e. write data = 0xxx xxxx, read data = 1xxx xxxx). Once the programming cycle is complete,  $I/O_7$  will reflect true data.

#### Toggle Bit ( $I/O_6$ )

The X28HC16 also provides another method for determining when the internal write cycle is complete. During the internal programming cycle  $I/O_6$  will toggle from one to zero and zero to one on subsequent attempts to read the device. When the internal cycle is complete the toggling will cease and the device will be accessible for additional read or write operations.