

*FlexROM*TM-Based 8-Bit CMOS Microcontroller Series

Devices Included in this Data Sheet:

- PIC16FR54A
- PIC16FR58A

High-Performance RISC CPU:

- Only 33 single word instructions to learn
- All instructions are single cycle (200 ns) except for program branches which are two-cycle
- Operating speed: DC - 20 MHz clock input
DC - 200 ns instruction cycle

Device	Pins	I/O	FlexROM	RAM
PIC16FR54A	18	12	512	25
PIC16FR58A	18	12	2K	73

- 12-bit wide instructions
- 8-bit wide data path
- Seven special function hardware registers
- Two-level deep hardware stack
- Direct, indirect and relative addressing modes for data and instructions

Peripheral Features:

- 8-bit real time clock/counter (TMR0) with 8-bit programmable prescaler
- Power-On Reset (POR)
- Device Reset Timer (DRT)
- Watchdog Timer (WDT) with its own on-chip RC oscillator for reliable operation
- Selectable code-protection
- Power saving SLEEP mode
- Selectable oscillator options:
 - RC: Low-cost RC oscillator
 - XT: Standard crystal/resonator
 - HS: High-speed crystal/resonator
 - LP: Power saving, low frequency crystal

Pin Configurations

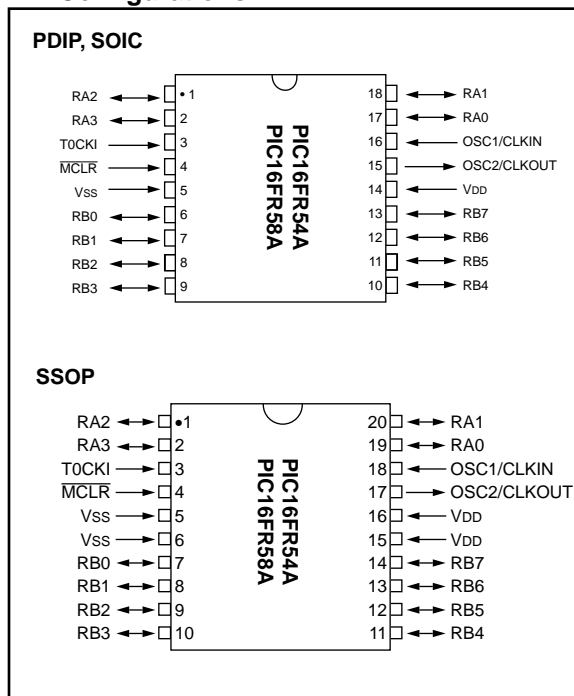

CMOS Technology:

- Low-power, high-speed CMOS *FlexROM* technology
- Fully static design
- Wide-operating voltage range:
 - *FlexROM* Commercial/Industrial 2.5V to 6.25V
- Low-power consumption
 - < 2 mA typical @ 5V, 4 MHz
 - 15 μ A typical @ 3V, 32 kHz
 - < 0.6 μ A typical standby current (with WDT disabled) @ 3V, 0°C to 70°C

Enhanced PIC16FR5X

1.0 GENERAL DESCRIPTION

The Enhanced PIC16FR5X from Microchip Technology is a family of low-cost, high performance, 8-bit, fully static, *FlexROM*-based CMOS microcontrollers. This family is pin and software compatible with the PIC16FR5X family of devices in a new enhanced process technology. It employs a RISC architecture with only 33 single word/single cycle instructions. All instructions are single cycle (200 ns) except for program branches which take two cycles. The Enhanced PIC16FR5X delivers performance an order of magnitude higher than its competitors in the same price category. The 12-bit wide instructions are highly symmetrical resulting in 2:1 code compression over other 8-bit microcontrollers in its class. The easy to use and easy to remember instruction set reduces development time significantly.

The Enhanced PIC16FR5X products are equipped with special features that reduce system cost and power requirements. The Power-On Reset (POR) and Device Reset Timer (DRT) eliminate the need for external reset circuitry. There are four oscillator configurations to choose from, including the power-saving LP (Low Power) oscillator and cost saving RC oscillator. Power saving SLEEP mode, Watchdog Timer and code protection features improve system cost, power and reliability.

The PIC16FR5X products are supported by a full-featured macro assembler, a software simulator, an in-circuit emulator, a 'C' compiler, fuzzy logic support tools. All the tools are supported on IBM[®] PC and compatible machines.

1.1 Applications

The PIC16FR5X series fits perfectly in applications ranging from high-speed automotive and appliance motor control to low-power remote transmitters/receivers, pointing devices and telecom processors. The *FlexROM* technology makes customizing application programs (transmitter codes, motor speeds, receiver frequencies, etc.) extremely fast and convenient. The small footprint packages, for through hole or surface mounting, make this microcontroller series perfect for applications with space limitations. Low-cost, low-power, high performance, ease of use and I/O flexibility make the PIC16FR5X series very versatile even in areas where no microcontroller use has been considered before (e.g., timer functions, replacement of "glue" logic in larger systems, coprocessor applications).

Enhanced PIC16FR5X

TABLE 1-1: ENHANCED PIC16FR5X FAMILY OF DEVICES

	Maximum Frequency of Operation (MHz)		FlexROM Program Memory (words)	RAM Data Memory (bytes)	Timer Module(s)	I/O Pins	Voltage Range (Volts)	Number of Instructions	Packages
	Clock	Memory	Peripherals	Features					
PIC16FR54A	20	512	25	TMR0	12	2.5-6.25	33	18-pin DIP, SOIC; 20-pin SSOP	
PIC16FR58A	20	2K	73	TMR0	12	2.5-6.25	33	18-pin DIP, SOIC; 20-pin SSOP	

Legend: All PIC16/17 Family devices have Power-On Reset, selectable Watchdog Timer, selectable code protect and high I/O current capability.

Note: Please contact your local sales office for availability of these devices.

Enhanced PIC16FR5X

2.0 ARCHITECTURAL OVERVIEW

This section provides information on the architecture of the Enhanced PIC16FR5X. For information on operation of the peripherals, electrical specifications, etc., please refer to the Enhanced PIC16C5X data sheet.

FIGURE 2-1: PIC16FR5X SERIES BLOCK DIAGRAM

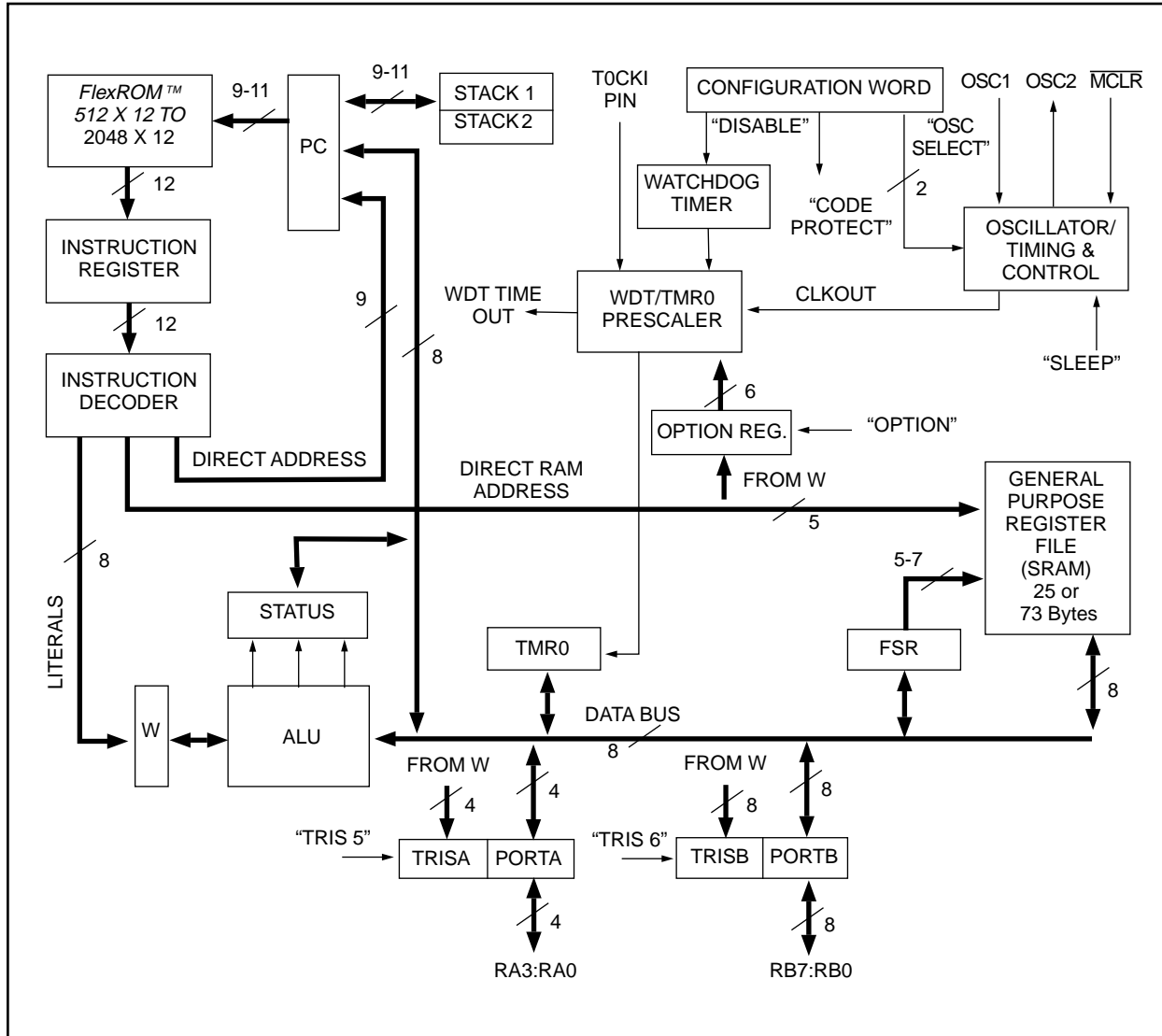

Enhanced PIC16FR5X

TABLE 2-1: PINOUT DESCRIPTION - PIC16FR54A, PIC16FR58A

Name	DIP, SOIC No.	SSOP No.	I/O/P Type	Input Levels	Description
RA0	17	19	I/O	TTL	Bi-directional I/O port
RA1	18	20	I/O	TTL	
RA2	1	1	I/O	TTL	
RA3	2	2	I/O	TTL	
RB0	6	7	I/O	TTL	Bi-directional I/O port
RB1	7	8	I/O	TTL	
RB2	8	9	I/O	TTL	
RB3	9	10	I/O	TTL	
RB4	10	11	I/O	TTL	
RB5	11	12	I/O	TTL	
RB6	12	13	I/O	TTL	
RB7	13	14	I/O	TTL	
T0CKI	3	3	I	ST	Clock input to Timer0. Must be tied to Vss or VDD, if not in use, to reduce current consumption.
$\overline{\text{MCLR}}$	4	4	I	ST	Master clear (reset) input. This pin is an active low reset to the device.
OSC1/CLKIN	16	18	I	ST	Oscillator crystal input/external clock source input.
OSC2/CLKOUT	15	17	O	—	Oscillator crystal output. Connects to crystal or resonator in crystal oscillator mode. In RC mode, OSC2 pin outputs CLKOUT which has 1/4 the frequency of OSC1, and denotes the instruction cycle rate.
VDD	14	15,16	P	—	Positive supply for logic and I/O pins.
Vss	5	5,6	P	—	Ground reference for logic and I/O pins.

Legend: I = input, O = output, I/O = input/output,
P = power, — = Not Used, TTL = TTL input,
ST = Schmitt Trigger input

Enhanced PIC16FR5X

3.0 MEMORY ORGANIZATION

FIGURE 3-1: PIC16FR54A PROGRAM MEMORY MAP AND STACK

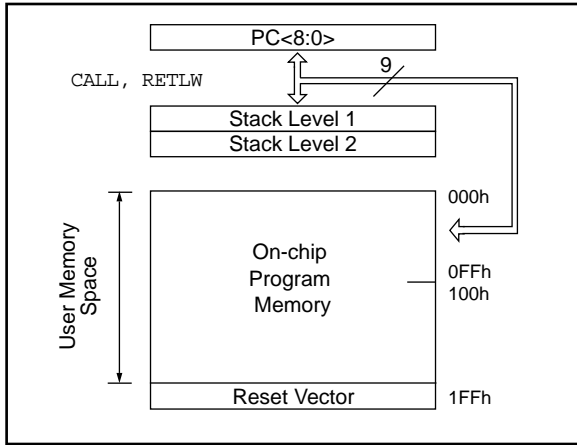

FIGURE 3-2: PIC16FR58A PROGRAM MEMORY MAP AND STACK

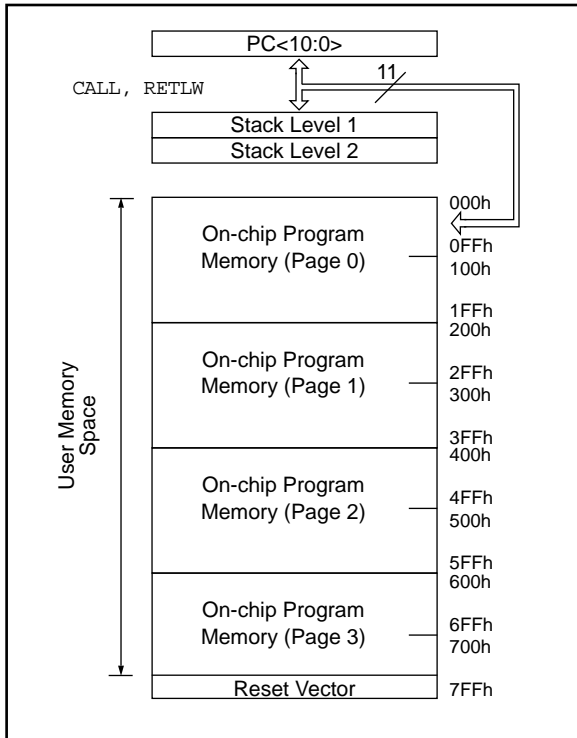

FIGURE 3-3: PIC16FR54A REGISTER FILE MAP

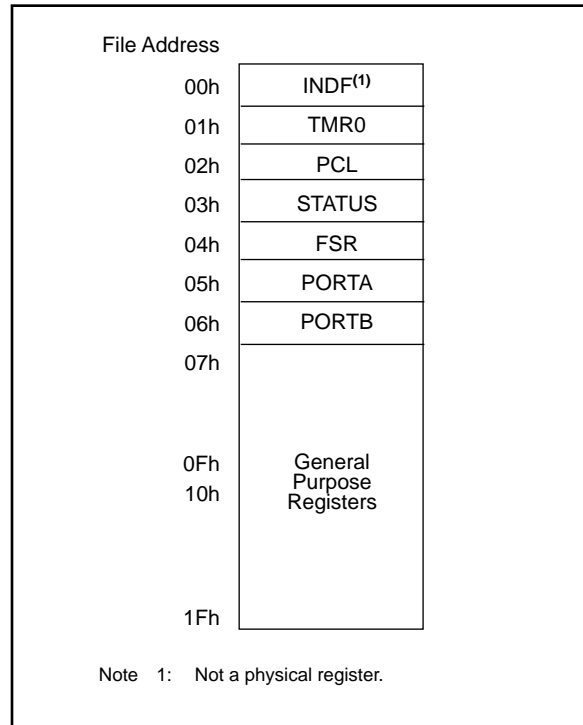

FIGURE 3-4: PIC16FR58A REGISTER FILE MAP

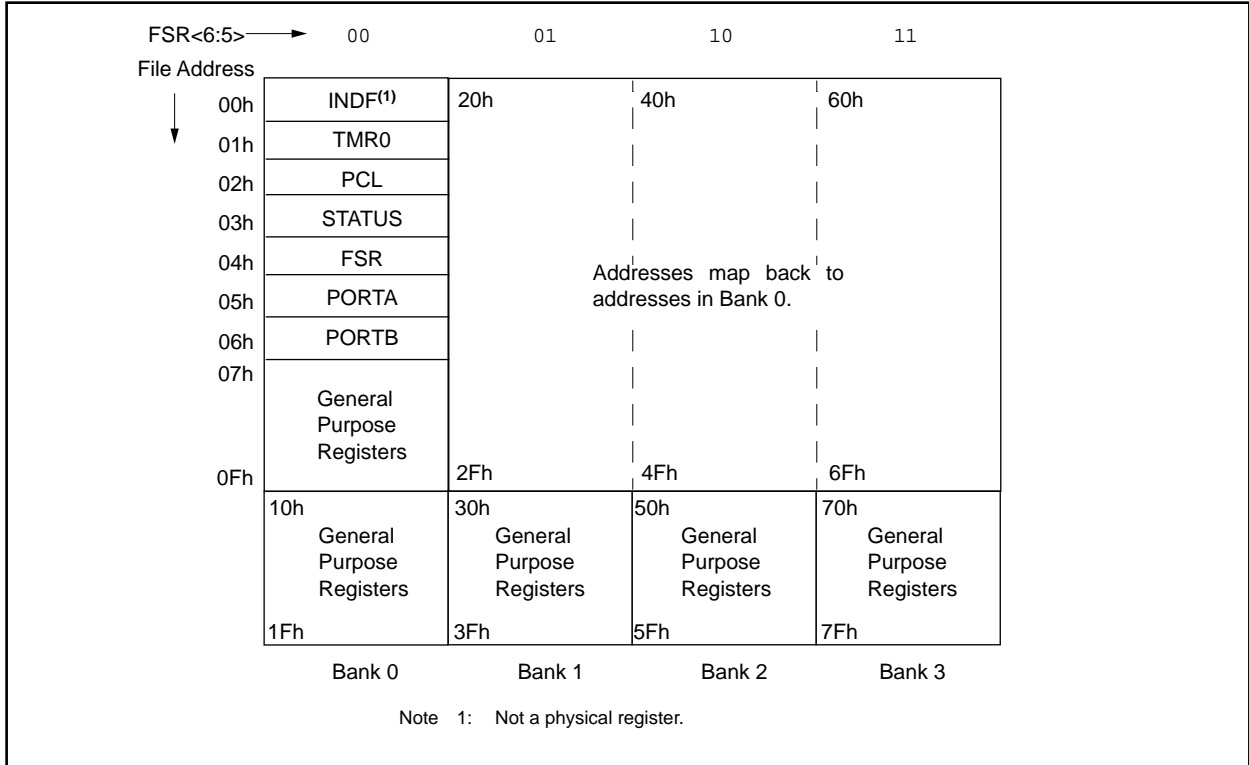

TABLE 3-1: SPECIAL FUNCTION REGISTER SUMMARY

Address	Name	Bit 7	Bit 6	Bit 5	Bit 4	Bit 3	Bit 2	Bit 1	Bit 0	Value on Power-On Reset	Value on MCLR and WDT Reset
N/A	TRIS	I/O control registers (TRISA, TRISB, TRISC)								1111 1111	1111 1111
N/A	OPTION	Contains control bits to configure Timer0 and Timer0/WDT prescaler								--11 1111	--11 1111
00h	INDF	Uses contents of FSR to address data memory (not a physical register)								xxxx xxxx	uuuu uuuu
01h	TMR0	8-bit real-time clock/counter								xxxx xxxx	uuuu uuuu
02h ⁽¹⁾	PCL	Low order 8 bits of PC								1111 1111	1111 1111
03h	STATUS	PA2	PA1	PA0	\overline{TO}	\overline{PD}	Z	DC	C	0001 1xxx	000q quuu
04h	FSR	Indirect data memory address pointer								1xxx xxxx	1uuu uuuu
05h	PORTA	—	—	—	—	RA3	RA2	RA1	RA0	---- xxxx	---- uuuu
06h	PORTB	RB7	RB6	RB5	RB4	RB3	RB2	RB1	RB0	xxxx xxxx	uuuu uuuu

Legend: Shaded boxes = unimplemented or unused, — = unimplemented, read as '0' (if applicable)
 x = unknown, u = unchanged, q = value depends on condition.

Note 1: The upper byte of the Program Counter is not directly accessible. See Section 4.5 of the Enhanced PIC16C5X data sheet (DS30236B) for an explanation of how to access these bits.

Note 2: File address 07h is a general purpose register on the PIC16FR54A and PIC16FR58A.

Enhanced PIC16FR5X

CONNECTING TO MICROCHIP BBS

Connect worldwide to the Microchip BBS using the CompuServe® communications network. In most cases a local call is your only expense. The Microchip BBS connection does not use CompuServe membership services, therefore, **you do not need CompuServe membership to join Microchip's BBS.**

There is **no charge** for connecting to the BBS, except toll charge to CompuServe access number, where applicable. You do not need to be a CompuServe member to take advantage of this connection (you never actually log in to CompuServe).

The procedure to connect will vary slightly from country to country. Please check with your local CompuServe agent for details if you have a problem. CompuServe service allows multiple users at baud rates up to 14,400 bps.

The following connect procedure applies in most locations:

1. Set your modem to 8-bit, No parity, and One stop (8N1). This is not the normal CompuServe setting which is 7E1.
2. Dial your local CompuServe access number.
3. Depress **<ENTER>** and a garbage string will appear because CompuServe is expecting a 7E1 setting.
4. Type **+**, depress **<ENTER>** and Host Name: will appear.
5. Type **MCHIPBBS**, depress **< ENTER>** and you will be connected to the Microchip BBS.

In the United States, to find CompuServe's phone number closest to you, set your modem to 7E1 and dial (800) 848-4480 for 300-2400 baud or (800) 331-7166 for 9600-14400 baud connection. After the system responds with Host Name:

Type, **NETWORK**, depress **< ENTER>** and follow CompuServe's directions.

For voice information (or calling from overseas), you may call (614) 723-1550 for your local CompuServe number.

ACCESS TO THE INTERNET

Microchip's current WWW address is listed on the back page of this data sheet under Worldwide Sales & Service - Americas - Corporate Office.

Trademarks:

The Microchip name, logo and PIC are registered trademarks in the U.S.A. and other countries of Microchip Technology Incorporated in the U.S.A.

FlexROM is a trademark of Microchip Technology Incorporated.

IBM PC is a registered trademark of International Business Machines Corp.

CompuServe is a registered trademark of CompuServe Incorporated.

All other trademarks mentioned herein are the property of their respective companies.

READER RESPONSE

It is our intention to provide you with the best documentation possible to ensure successful use of your Microchip product. If you wish to provide your comments on organization, clarity, subject matter, and ways in which our documentation can better serve you, please FAX your comments to the Technical Publications Manager at (602) 786-7578.

Please list the following information, and use this outline to provide us with your comments about this Data Sheet.

To: Technical Publications Manager Total Pages Sent _____

RE: Reader Response

From: Name _____

Company _____

Address _____

City / State / ZIP / Country _____

Telephone: (_____) _____ - _____ FAX: (_____) _____ - _____

Application (optional): _____

Would you like a reply? ___ Y ___ N

Device: **Enhanced PIC16FR5X** Literature Number: **DS40124A**

Questions:

1. What are the best features of this document? _____

2. How does this document meet your hardware and software development needs? _____

3. Do you find the organization of this data sheet easy to follow? If not, why? _____

4. What additions to the data sheet do you think would enhance the structure and subject? _____

5. What deletions from the data sheet could be made without affecting the overall usefulness? _____

6. Is there any incorrect or misleading information (what and where)? _____

7. How would you improve this document? _____

8. How would you improve our software, systems, and silicon products? _____

Enhanced PIC16FR5X

ENHANCED PIC16FR5X PRODUCT IDENTIFICATION SYSTEM

To order or obtain information, e.g., on pricing or delivery, refer to the factory or the listed sales office.

<u>PART NO.</u>	<u>-XX</u>	<u>X</u>	<u>/XX</u>	<u>XXX</u>	
Device	Frequency Range	Temperature Range	Package	Pattern	
Device	PIC16FR5XA ⁽²⁾ , PIC16FR5XAT ⁽³⁾ PIC16LFR5XA ⁽²⁾ , PIC16LFR5XAT ⁽³⁾				Examples: a) PIC16FR54A -04/P 301 = Commercial temp., PDIP package, 4 MHz, normal VDD limits, pattern #301. b) PIC16LFR58A - 04I/SO123 = Industrial temp., SOIC package, 4 MHz, Extended VDD limits, pattern #123. Note 1: b = blank 2: FR = <i>FlexROM</i> Version, Standard VDD range LFR = <i>FlexROM</i> Version, Extended VDD range 3: T = in tape and reel - SOIC, SSOP packages only.
Frequency Range	04 = 4 MHz 10 = 10 MHz 20 = 20 MHz				
Temperature Range	b ⁽¹⁾ = 0°C to +70°C (Commercial) I = -40°C to +85°C (Industrial)				
Package	P = PDIP SO = SOIC (Gull Wing, 300 mil body) SS = SSOP (209 mil body)				
Pattern	3-digit Pattern Code for <i>FlexROM</i> (blank otherwise)				

Sales and Support

Products supported by a preliminary Data Sheet may possibly have an errata sheet describing minor operational differences and recommended workarounds. To determine if an errata sheet exists for a particular device, please contact one of the following:

1. Your local Microchip sales office (see below)
2. The Microchip Corporate Literature Center U.S. FAX: (602) 786-7277
3. The Microchip's Bulletin Board, via your local CompuServe number (CompuServe membership NOT required).

Please specify which device, revision of silicon and Data Sheet (include Literature #) you are using.

For latest version information and upgrade kits for Microchip Development Tools, please call 1-800-755-2345 or 1-602-786-7302.

NOTES:

WORLDWIDE SALES & SERVICE

AMERICAS

Corporate Office

Microchip Technology Inc.
2355 West Chandler Blvd.
Chandler, AZ 85224-6199
Tel: 602 786-7200 Fax: 602 786-7277
Technical Support: 602 786-7627
Web: <http://www.mchip.com/microchip>

Atlanta

Microchip Technology Inc.
500 Sugar Mill Road, Suite 200B
Atlanta, GA 30350
Tel: 770 640-0034 Fax: 770 640-0307

Boston

Microchip Technology Inc.
5 Mount Royal Avenue
Marlborough, MA 01752
Tel: 508 480-9990 Fax: 508 480-8575

Chicago

Microchip Technology Inc.
333 Pierce Road, Suite 180
Itasca, IL 60143
Tel: 708 285-0071 Fax: 708 285-0075

Dallas

Microchip Technology Inc.
14651 Dallas Parkway, Suite 816
Dallas, TX 75240-8809
Tel: 214 991-7177 Fax: 214 991-8588

Dayton

Microchip Technology Inc.
Suite 150
Two Prestige Place
Miamisburg, OH 45342
Tel: 513 291-1654 Fax: 513 291-9175

Los Angeles

Microchip Technology Inc.
18201 Von Karman, Suite 1090
Irvine, CA 92715
Tel: 714 263-1888 Fax: 714 263-1338

AMERICAS (continued)

New York

Microchip Technology Inc.
150 Motor Parkway, Suite 416
Hauppauge, NY 11788
Tel: 516 273-5305 Fax: 516 273-5335

San Jose

Microchip Technology Inc.
2107 North First Street, Suite 590
San Jose, CA 95131
Tel: 408 436-7950 Fax: 408 436-7955

CANADA

Microchip Technology Inc.
5925 Airport Road, Suite 200
Mississauga, Ontario L4V 1W1, Canada
Tel: 905 405-6279 Fax: 905 405-6253

ASIA/PACIFIC

Hong Kong

Microchip Technology
Unit No. 3002-3004, Tower 1
Metroplaza
223 Hing Fong Road
Kwai Fong, N.T. Hong Kong
Tel: 852 2 401 1200 Fax: 852 2 401 3431

Korea

Microchip Technology
168-1, Youngbo Bldg. 3 Floor
Samsung-Dong, Kangnam-Ku,
Seoul, Korea
Tel: 82 2 554 7200 Fax: 82 2 558 5934

Singapore

Microchip Technology
200 Middle Road
#10-03 Prime Centre
Singapore 188980
Tel: 65 334 8870 Fax: 65 334 8850

Taiwan

Microchip Technology
10F-1C 207
Tung Hua North Road
Taipei, Taiwan, ROC
Tel: 886 2 717 7175 Fax: 886 2 545 0139

EUROPE

United Kingdom

Arizona Microchip Technology Ltd.
Unit 6, The Courtyard
Meadow Bank, Furlong Road
Bourne End, Buckinghamshire SL8 5AJ
Tel: 44 1 628 850303 Fax: 44 1 628 850178

France

Arizona Microchip Technology SARL
Zone Industrielle de la Bonde
2 Rue du Buisson aux Fraises
91300 Massy - France
Tel: 33 1 69 53 63 20 Fax: 33 1 69 30 90 79

Germany

Arizona Microchip Technology GmbH
Gustav-Heinemann-Ring 125
D-81739 Muenchen, Germany
Tel: 49 89 627 144 0 Fax: 49 89 627 144 44

Italy

Arizona Microchip Technology SRL
Centro Direzionale Colleoni
Palazzo Taurus 1 V. Le Colleoni 1
20041 Agrate Brianza, Milan Italy
Tel: 39 39 689 9939 Fax: 39 39 689 9883

JAPAN

Microchip Technology Intl. Inc.
Benex S-1 6F
3-18-20, Shin Yokohama
Kohoku-Ku, Yokohama
Kanagawa 222 Japan
Tel: 81 45 471 6166 Fax: 81 45 471 6122

4/08/96



MICROCHIP

All rights reserved. © 1996, Microchip Technology Incorporated, USA.

Information contained in this publication regarding device applications and the like is intended through suggestion only and may be superseded by updates. No representation or warranty is given and no liability is assumed by Microchip Technology Incorporated with respect to the accuracy or use of such information, or infringement of patents or other intellectual property rights arising from such use or otherwise. Use of Microchip's products as critical components in life support systems is not authorized except with express written approval by Microchip. No licenses are conveyed, implicitly or otherwise, under any intellectual property rights. The Microchip logo and name are registered trademarks of Microchip Technology Inc. All rights reserved. All other trademarks mentioned herein are the property of their respective companies.