

64K (8K x 8) CMOS EEPROM

FEATURES

- Fast Read Access Time—150 ns
- CMOS Technology for Low Power Dissipation
 - 30 mA Active
 - 100 μ A Standby
- Fast Byte Write Time—200 μ s or 1 ms
- Data Retention >200 years
- High Endurance - Minimum 100,000 Erase/Write Cycles
- Automatic Write Operation
 - Internal Control Timer
 - Auto-Clear Before Write Operation
 - On-Chip Address and Data Latches
- Data Polling
- Ready/Busy
- Chip Clear Operation
- Enhanced Data Protection
 - VCC Detector
 - Pulse Filter
 - Write Inhibit
- Electronic Signature for Device Identification
- 5-Volt-Only Operation
- Organized 8Kx8 JEDEC Standard Pinout
 - 28-pin Dual-In-Line Package
 - 32-pin PLCC Package
 - 28-pin SOIC Package
- Available for Extended Temperature Ranges:
 - Commercial: 0°C to +70°C
 - Industrial: -40°C to +85°C

DESCRIPTION

The Microchip Technology Inc. 28C64A is a CMOS 64K non-volatile electrically Erasable PROM. The 28C64A is accessed like a static RAM for the read or write cycles without the need of external components. During a "byte write", the address and data are latched internally, freeing the microprocessor address and data bus for other operations. Following the initiation of write cycle, the device will go to a busy state and automatically clear and write the latched data using an internal control timer. To determine when the write cycle is complete, the user has a choice of monitoring the Ready/Busy output or using Data polling. The Ready/Busy pin is an open drain output, which allows easy configuration in wired-or systems. Alternatively, Data polling allows the user to read the location last written to when the write operation is complete. CMOS design and processing enables this part to be used in systems where reduced power consumption and reliability are required. A complete family of packages is offered to provide the utmost flexibility in applications.

PACKAGE TYPES

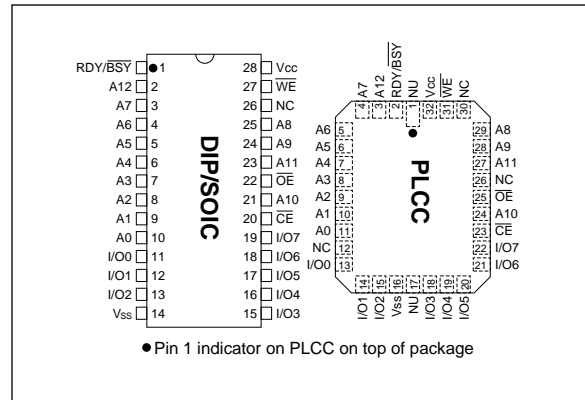

BLOCK DIAGRAM

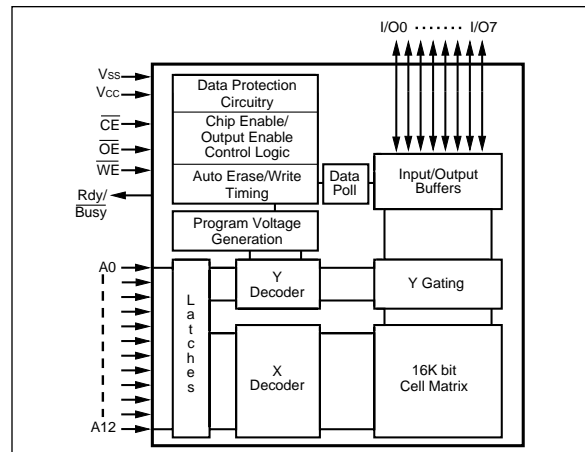

28C64A

1.0 ELECTRICAL CHARACTERISTICS

1.1 MAXIMUM RATINGS*

V_{CC} and input voltages w.r.t. V_{SS} -0.6V to + 6.25V
 Voltage on \overline{OE} w.r.t. V_{SS} -0.6V to +13.5V
 Voltage on A9 w.r.t. V_{SS} -0.6V to +13.5V
 Output Voltage w.r.t. V_{SS} -0.6V to V_{CC}+0.6V
 Storage temperature -65°C to +125°C
 Ambient temp. with power applied -50°C to +95°C

*Notice: Stresses above those listed under "Maximum Ratings" may cause permanent damage to the device. This is a stress rating only and functional operation of the device at those or any other conditions above those indicated in the operation listings of this specification is not implied. Exposure to maximum rating conditions for extended periods may affect device reliability.

TABLE 1-1: PIN FUNCTION TABLE

Name	Function
A0 - A12	Address Inputs
\overline{CE}	Chip Enable
\overline{OE}	Output Enable
\overline{WE}	Write Enable
I/O0 - I/O7	Data Inputs/Outputs
RDY/ \overline{Busy}	Ready/ \overline{Busy}
V _{CC}	+5V Power Supply
V _{SS}	Ground
NC	No Connect No Internal Connection
NU	Not Used No External Connection is Allowed

TABLE 1-2: READ/WRITE OPERATION DC CHARACTERISTIC

V _{CC} = +5V ±10% Commercial (C): Tamb = 0°C to +70°C Industrial (I): Tamb = -40°C to +85°C						
Parameter	Status	Symbol	Min	Max	Units	Conditions
Input Voltages	Logic '1' Logic '0'	V _{IH} V _{IL}	2.0 -0.1	V _{CC} +1 0.8	V V	
Input Leakage	—	I _{LI}	-10	10	μA	V _{IN} = -0.1V to V _{CC} +1
Input Capacitance	—	C _{IN}	—	10	pF	V _{IN} = 0V; Tamb = 25°C; f = 1 MHz (Note 2)
Output Voltages	Logic '1' Logic '0'	V _{OH} V _{OL}	2.4	0.45	V V	I _{OH} = -400 μA I _{OL} = 2.1 mA
Output Leakage	—	I _{LO}	-10	10	μA	V _{OUT} = -0.1V to V _{CC} +0.1V
Output Capacitance	—	C _{OUT}	—	12	pF	V _{IN} = 0V; Tamb = 25°C; f = 1 MHz (Note 2)
Power Supply Current, Active	TTL input	I _{CC}	—	30	mA	f = 5 MHz (Note 1) V _{CC} = 5.5V
Power Supply Current, Standby	TTL input TTL input CMOS input	I _{CC(S)TTL} I _{CC(S)TTL} I _{CC(S)CMOS}	—	2 3 100	mA mA μA	\overline{CE} = V _{IH} (0°C to +70°C) \overline{CE} = V _{IH} (-40°C to +85°C) \overline{CE} = V _{CC} -0.3 to V _{CC} +1 \overline{OE} = \overline{WE} = V _{CC} All other inputs equal V _{CC} or V _{SS}

Note 1: AC power supply current above 5MHz: 2mA/MHz.
 2: Not 100% tested.

TABLE 1-3: READ OPERATION AC CHARACTERISTICS

Parameter	Symbol	28C64A-15		28C64A-20		28C64A-25		Units	Conditions
		Min	Max	Min	Max	Min	Max		
		AC Testing Waveform: $V_{IH} = 2.4V$; $V_{IL} = 0.45V$; $V_{OH} = 2.0V$; $V_{OL} = 0.8V$ Output Load: 1 TTL Load + 100 pF Input Rise and Fall Times: 20 ns Ambient Temperature: Commercial (C): $T_{amb} = 0^{\circ}C$ to $+70^{\circ}C$ Industrial (I): $T_{amb} = -40^{\circ}C$ to $+85^{\circ}C$							
Address to Output Delay	t_{ACC}	—	150	—	200	—	250	ns	$\overline{OE} = \overline{CE} = V_{IL}$
\overline{CE} to Output Delay	t_{CE}	—	150	—	200	—	250	ns	$\overline{OE} = V_{IL}$
\overline{OE} to Output Delay	t_{OE}	—	70	—	80	—	100	ns	$\overline{CE} = V_{IL}$
\overline{CE} or \overline{OE} High to Output Float	t_{OFF}	0	50	0	55	0	70	ns	(Note 1)
Output Hold from Address, \overline{CE} or \overline{OE} , whichever occurs first.	t_{OH}	0	—	0	—	0	—	ns	(Note 1)
Endurance	—	1M	—	1M	—	1M	—	cycles	$25^{\circ}C$, $V_{CC} = 5.0V$, Block Mode (Note 2)

Note 1: Not 100% tested.

2: This parameter is not tested but guaranteed by characterization. For endurance estimates in a specific application, please consult the Total Endurance Model which can be obtained on our BBS or website.

FIGURE 1-1: READ WAVEFORMS

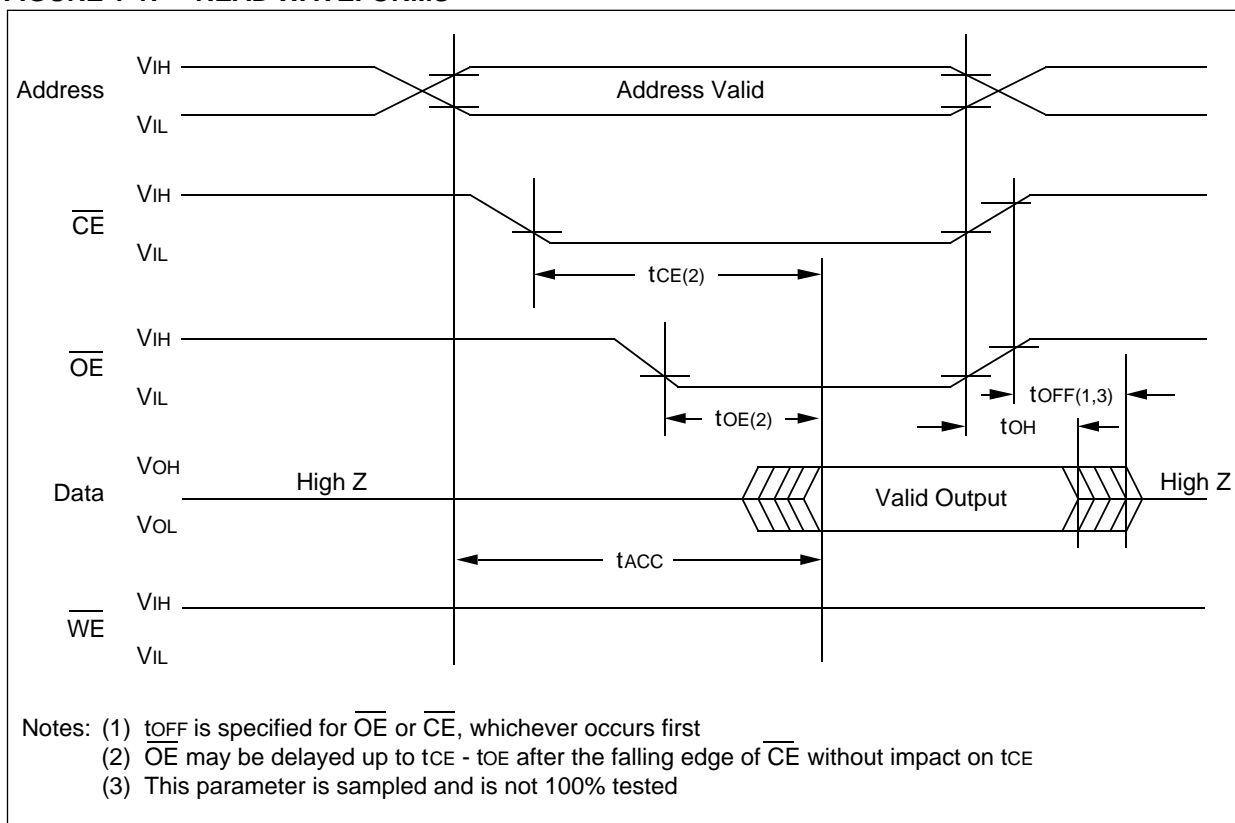

28C64A

TABLE 1-4: BYTE WRITE AC CHARACTERISTICS

Parameter	Symbol	Min	Max	Units	Remarks
AC Testing Waveform:		$V_{IH} = 2.4V$; $V_{IL} = 0.45V$; $V_{OH} = 2.0V$; $V_{OL} = 0.8V$ Output Load: 1 TTL Load + 100 pF Input Rise/Fall Times: 20 ns Ambient Temperature: Commercial (C): $T_{amb} = 0^{\circ}C$ to $+70^{\circ}C$ Industrial (I): $T_{amb} = -40^{\circ}C$ to $+85^{\circ}C$			
Address Set-Up Time	tAS	10	—	ns	
Address Hold Time	tAH	50	—	ns	
Data Set-Up Time	tDS	50	—	ns	
Data Hold Time	tDH	10	—	ns	
Write Pulse Width	twPL	100	—	ns	Note 1
Write Pulse High Time	twPH	50	—	ns	
\overline{OE} Hold Time	toEH	10	—	ns	
\overline{OE} Set-Up Time	toES	10	—	ns	
Data Valid Time	tDV	—	1000	ns	Note 2
Time to Device Busy	tDB	2	50	ns	
Write Cycle Time (28C64A)	twC	—	1	ms	0.5 ms typical
Write Cycle Time (28C64AF)	twC	—	200	μs	100 μs typical

- Note 1: A write cycle can be initiated by \overline{CE} or \overline{WE} going low, whichever occurs last. The data is latched on the positive edge \overline{WE} , whichever occurs first.
- 2: Data must be valid within 1000ns max. after a write cycle is initiated and must be stable at least until tDH after the positive edge of \overline{WE} or \overline{CE} , whichever occurs first.

FIGURE 1-2: PROGRAMMING WAVEFORMS

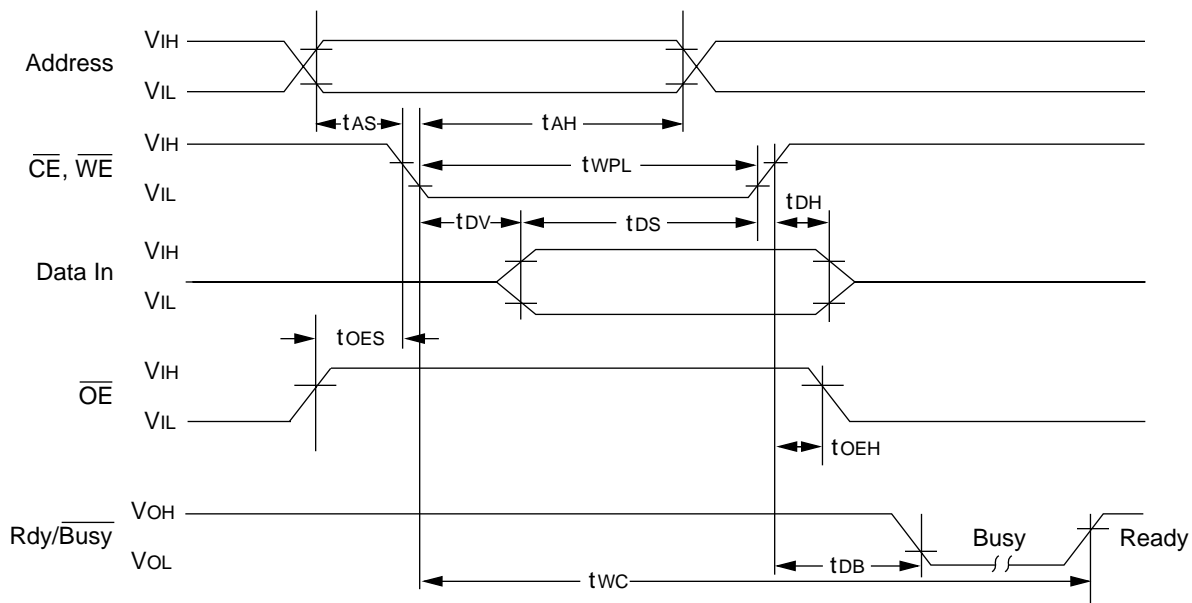

FIGURE 1-3: DATA POLLING WAVEFORMS



FIGURE 1-4: CHIP CLEAR WAVEFORMS

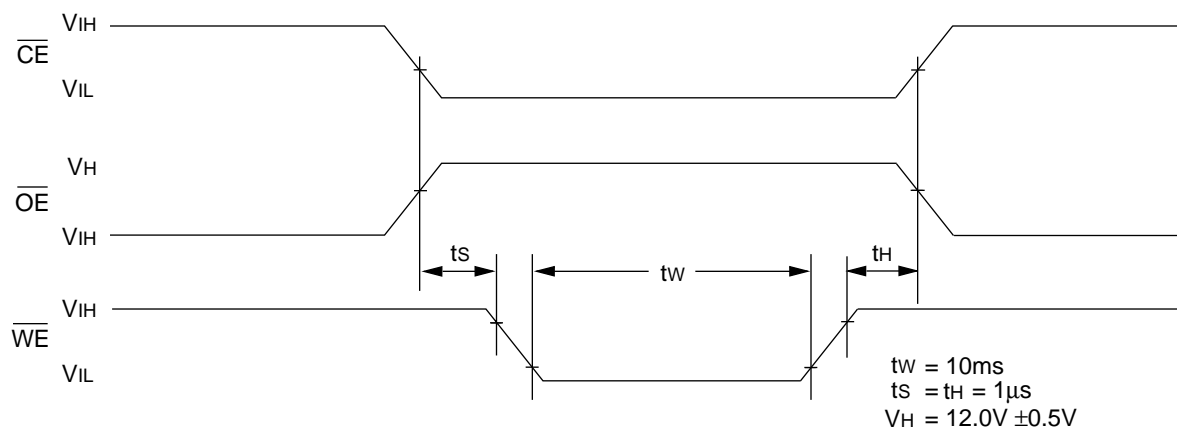

TABLE 1-5: SUPPLEMENTARY CONTROL

Mode	\overline{CE}	\overline{OE}	\overline{WE}	A9	Vcc	I/O \overline{I}
Chip Clear	VIL	VIH	VIL	X	Vcc	
Extra Row Read	VIL	VIL	VIH	A9 = VH	Vcc	Data Out
Extra Row Write	*	VIH	*	A9 = VH	Vcc	Data In

Note: $V_H = 12.0\text{V} \pm 0.5\text{V}$. *Pulsed per programming waveforms.

2.0 DEVICE OPERATION

The Microchip Technology Inc. 28C64A has four basic modes of operation—read, standby, write inhibit, and byte write—as outlined in the following table.

Operation Mode	\overline{CE}	\overline{OE}	\overline{WE}	I/O	Rdy/Busy (1)
Read	L	L	H	DOUT	H
Standby	H	X	X	High Z	H
Write Inhibit	H	X	X	High Z	H
Write Inhibit	X	L	X	High Z	H
Write Inhibit	X	X	H	High Z	H
Byte Write	L	H	L	DIN	L
Byte Clear	Automatic Before Each "Write"				

Note 1: Open drain output.

2: X = Any TTL level.

2.1 Read Mode

The 28C64A has two control functions, both of which must be logically satisfied in order to obtain data at the outputs. Chip enable (\overline{CE}) is the power control and should be used for device selection. Output Enable (\overline{OE}) is the output control and is used to gate data to the output pins independent of device selection. Assuming that addresses are stable, address access time (tACC) is equal to the delay from \overline{CE} to output (tCE). Data is available at the output tOE after the falling edge of \overline{OE} , assuming that \overline{CE} has been low and addresses have been stable for at least tACC-tOE.

2.2 Standby Mode

The 28C64A is placed in the standby mode by applying a high signal to the \overline{CE} input. When in the standby mode, the outputs are in a high impedance state, independent of the \overline{OE} input.

2.3 Data Protection

In order to ensure data integrity, especially during critical power-up and power-down transitions, the following enhanced data protection circuits are incorporated:

First, an internal VCC detect (3.3 volts typical) will inhibit the initiation of non-volatile programming operation when VCC is less than the VCC detect circuit trip.

Second, there is a \overline{WE} filtering circuit that prevents \overline{WE} pulses of less than 10 ns duration from initiating a write cycle.

Third, holding \overline{WE} or \overline{CE} high or \overline{OE} low, inhibits a write cycle during power-on and power-off (VCC).

2.4 Write Mode

The 28C64A has a write cycle similar to that of a Static RAM. The write cycle is completely self-timed and initiated by a low going pulse on the \overline{WE} pin. On the falling edge of \overline{WE} , the address information is latched. On rising edge, the data and the control pins (\overline{CE} and \overline{OE}) are latched. The Ready/Busy pin goes to a logic low level indicating that the 28C64A is in a write cycle which signals the microprocessor host that the system bus is free for other activity. When Ready/Busy goes back to a high, the 28C64A has completed writing and is ready to accept another cycle.

2.5 Data Polling

The 28C64A features \overline{Data} polling to signal the completion of a byte write cycle. During a write cycle, an attempted read of the last byte written results in the data complement of I/O7 (I/O0 to I/O6 are indeterminate). After completion of the write cycle, true data is available. \overline{Data} polling allows a simple read/compare operation to determine the status of the chip eliminating the need for external hardware.

2.6 Electronic Signature for Device Identification

An extra row of 32 bytes of EEPROM memory is available to the user for device identification. By raising A9 to 12V ±0.5V and using address locations 1FEO to 1FFF, the additional bytes can be written to or read from in the same manner as the regular memory array.

2.7 Chip Clear

All data may be cleared to 1's in a chip clear cycle by raising \overline{OE} to 12 volts and bringing the \overline{WE} and \overline{CE} low. This procedure clears all data, except for the extra row.

28C64A Product Identification System

To order or to obtain information, e.g., on pricing or delivery, please use the listed part numbers, and refer to the factory or the listed sales offices.

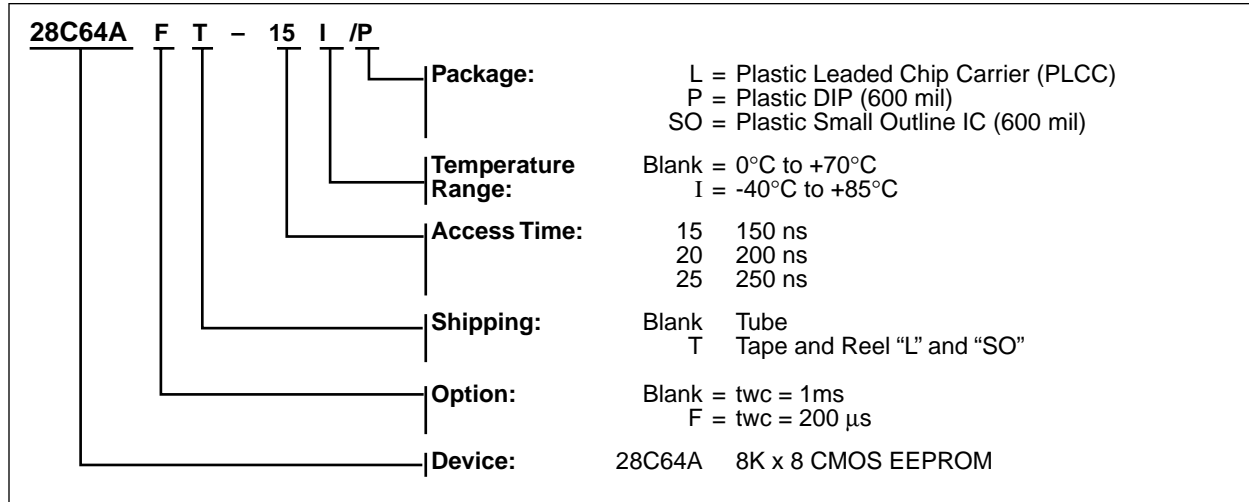



WORLDWIDE SALES AND SERVICE

AMERICAS

Corporate Office

Microchip Technology Inc.
2355 West Chandler Blvd.
Chandler, AZ 85224-6199
Tel: 480-786-7200 Fax: 480-786-7277
Technical Support: 480-786-7627
Web Address: <http://www.microchip.com>

Atlanta

Microchip Technology Inc.
500 Sugar Mill Road, Suite 200B
Atlanta, GA 30350
Tel: 770-640-0034 Fax: 770-640-0307

Boston

Microchip Technology Inc.
5 Mount Royal Avenue
Marlborough, MA 01752
Tel: 508-480-9990 Fax: 508-480-8575

Chicago

Microchip Technology Inc.
333 Pierce Road, Suite 180
Itasca, IL 60143
Tel: 630-285-0071 Fax: 630-285-0075

Dallas

Microchip Technology Inc.
4570 Westgrove Drive, Suite 160
Addison, TX 75248
Tel: 972-818-7423 Fax: 972-818-2924

Dayton

Microchip Technology Inc.
Two Prestige Place, Suite 150
Miamisburg, OH 45342
Tel: 937-291-1654 Fax: 937-291-9175

Detroit

Microchip Technology Inc.
Tri-Atria Office Building
32255 Northwestern Highway, Suite 190
Farmington Hills, MI 48334
Tel: 248-538-2250 Fax: 248-538-2260

Los Angeles

Microchip Technology Inc.
18201 Von Karman, Suite 1090
Irvine, CA 92612
Tel: 949-263-1888 Fax: 949-263-1338

New York

Microchip Technology Inc.
150 Motor Parkway, Suite 202
Hauppauge, NY 11788
Tel: 631-273-5305 Fax: 631-273-5335

San Jose

Microchip Technology Inc.
2107 North First Street, Suite 590
San Jose, CA 95131
Tel: 408-436-7950 Fax: 408-436-7955

AMERICAS (continued)

Toronto

Microchip Technology Inc.
5925 Airport Road, Suite 200
Mississauga, Ontario L4V 1W1, Canada
Tel: 905-405-6279 Fax: 905-405-6253

ASIA/PACIFIC

Hong Kong

Microchip Asia Pacific
Unit 2101, Tower 2
Metroplaza
223 Hing Fong Road
Kwai Fong, N.T., Hong Kong
Tel: 852-2-401-1200 Fax: 852-2-401-3431

Beijing

Microchip Technology, Beijing
Unit 915, 6 Chaoyangmen Bei Dajie
Dong Erhuan Road, Dongcheng District
New China Hong Kong Manhattan Building
Beijing 100027 PRC
Tel: 86-10-85282100 Fax: 86-10-85282104

India

Microchip Technology Inc.
India Liaison Office
No. 6, Legacy, Convent Road
Bangalore 560 025, India
Tel: 91-80-229-0061 Fax: 91-80-229-0062

Japan

Microchip Technology Intl. Inc.
Benex S-1 6F
3-18-20, Shinyokohama
Kohoku-Ku, Yokohama-shi
Kanagawa 222-0033 Japan
Tel: 81-45-471-6166 Fax: 81-45-471-6122

Korea

Microchip Technology Korea
168-1, Youngbo Bldg. 3 Floor
Samsung-Dong, Kangnam-Ku
Seoul, Korea
Tel: 82-2-554-7200 Fax: 82-2-558-5934

Shanghai

Microchip Technology
RM 406 Shanghai Golden Bridge Bldg.
2077 Yan'an Road West, Hong Qiao District
Shanghai, PRC 200335
Tel: 86-21-6275-5700 Fax: 86 21-6275-5060

ASIA/PACIFIC (continued)

Singapore

Microchip Technology Singapore Pte Ltd.
200 Middle Road
#07-02 Prime Centre
Singapore 188980
Tel: 65-334-8870 Fax: 65-334-8850

Taiwan, R.O.C

Microchip Technology Taiwan
10F-1C 207
Tung Hua North Road
Taipei, Taiwan, ROC
Tel: 886-2-2717-7175 Fax: 886-2-2545-0139

EUROPE

United Kingdom

Arizona Microchip Technology Ltd.
505 Eskdale Road
Wokingham
Berkshire, England RG41 5TU
Tel: 44 118 921 5858 Fax: 44-118 921-5835

Denmark

Microchip Technology Denmark ApS
Regus Business Centre
Lautrup hof 1-3
Ballerup DK-2750 Denmark
Tel: 45 4420 9895 Fax: 45 4420 9910

France

Arizona Microchip Technology SARL
Parc d'Activite du Moulin de Massy
43 Rue du Saule Trapu
Batiment A - 1er Etage
91300 Massy, France
Tel: 33-1-69-53-63-20 Fax: 33-1-69-30-90-79

Germany

Arizona Microchip Technology GmbH
Gustav-Heinemann-Ring 125
D-81739 München, Germany
Tel: 49-89-627-144 0 Fax: 49-89-627-144-44

Italy

Arizona Microchip Technology SRL
Centro Direzionale Colleoni
Palazzo Taurus 1 V. Le Colleoni 1
20041 Agrate Brianza
Milan, Italy
Tel: 39-039-65791-1 Fax: 39-039-6899883

11/15/99

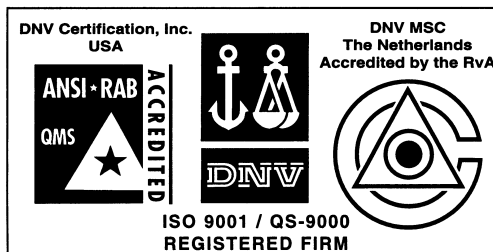

Microchip received QS-9000 quality system certification for its worldwide headquarters, design and water fabrication facilities in Chandler and Tempe, Arizona in July 1999. The Company's quality system processes and procedures are QS-9000 compliant for its PICmicro® 8-bit MCUs, KEELOC® code hopping devices, Serial EEPROMs and microperipheral products. In addition, Microchip's quality system for the design and manufacture of development systems is ISO 9001 certified.

All rights reserved. © 1999 Microchip Technology Incorporated. Printed in the USA. 11/99 Printed on recycled paper.

Information contained in this publication regarding device applications and the like is intended for suggestion only and may be superseded by updates. No representation or warranty is given and no liability is assumed by Microchip Technology Incorporated with respect to the accuracy or use of such information, or infringement of patents or other intellectual property rights arising from such use or otherwise. Use of Microchip's products as critical components in life support systems is not authorized except with express written approval by Microchip. No licenses are conveyed, implicitly or otherwise, under any intellectual property rights. The Microchip logo and name are registered trademarks of Microchip Technology Inc. in the U.S.A. and other countries. All rights reserved. All other trademarks mentioned herein are the property of their respective companies.